

USER'S GUIDE for the 200e ELECTRIC MUSIC BOX

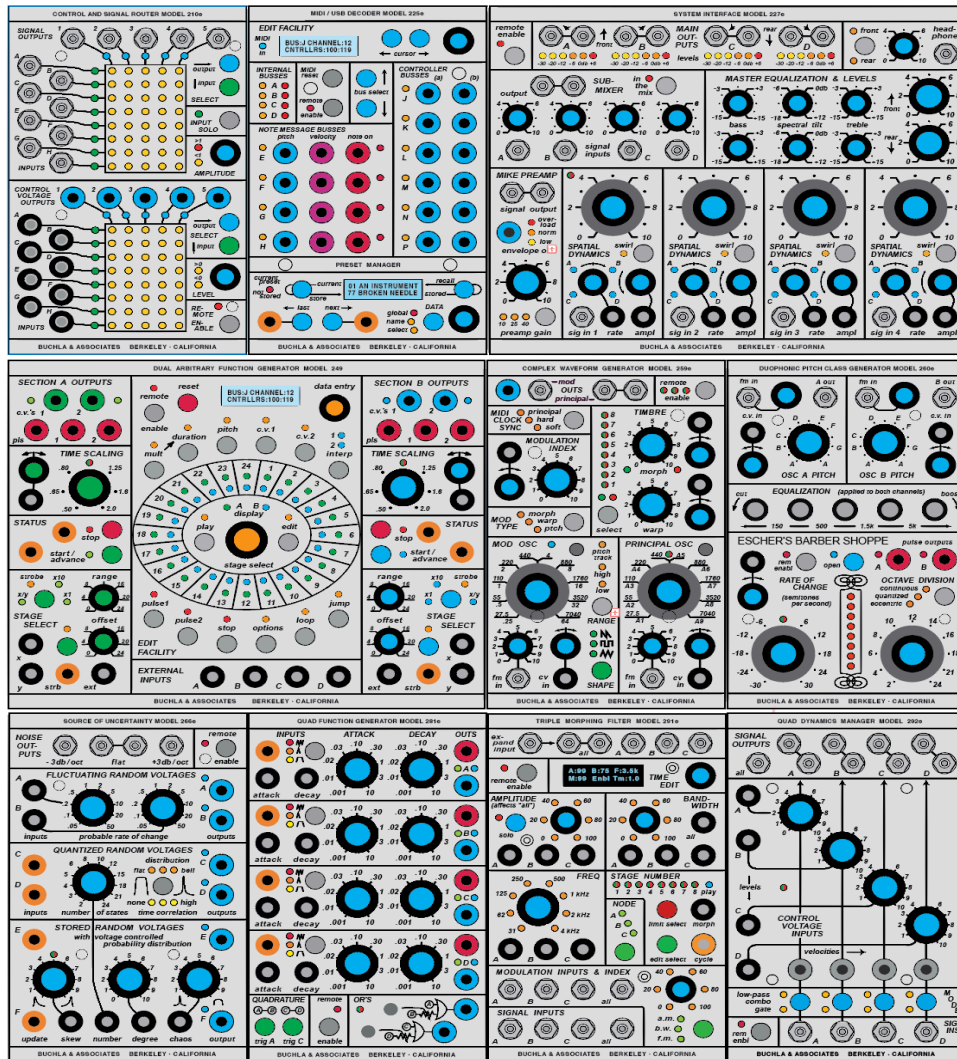

by the staff of
Buchla Electronic Musical Instruments
 V1.4 7/20/17
 © 2017 by Buchla Electronic Musical Instruments

Introduction

Welcome to the 200e system. These notes will acquaint you with your Buchla system, followed by individual descriptions of the various modules.

Important Safety Precautions

Do not disassemble this equipment. Refer all servicing to a qualified service engineer. But if you insist (or if you're definitely qualified), be sure to follow the next advice.

When installing, removing, or exchanging a module, please be certain to turn off the power supply. These modules are not designed to tolerate "hot patching" – power must be turned off before plugging in or unplugging modules.

Please note that both e-series and h-series connections and cables are keyed to be used in one direction only! Reversing the connectors can cause significant system damage.

We are not liable for damage or injury due to lack of common sense:

Do not use the 200 system near water; do not take it into your bath, sauna or hot tub. Take care not to spill liquids on or into the 200.

Locate the 200 away from heat sources such as radiators, fireplaces, stoves or solar cookers.

Exercise close supervision when using the instrument near children or when children are using it.

The 200's power supply is for indoor use only. Do not use a damaged or alternate supply. Refer all servicing to qualified personnel. There are no user serviceable parts or adjustments inside the 200h.

System/"Boat" set up

Retrieve the system from its case or carton, saving all packing materials, and confirming the presence of a DC power adaptor with an AC cord, and patchcords. If anything is missing, inform your source of the shortage. Place the system on a flat surface with the connectors pointing to the rear. Unfold and extend the support feet and unfasten any latches (if any) and prop up the system. Connect the power adaptor to AC (110VAC or 220VAC) and the 12-volt DC (center-positive) to the power input jack. Be sure to use the power supply with the Amperage rating appropriate for your system. Typical systems use power supplies rated 5.3A or higher. Systems fully loaded with 18 panels or more use the supplies rated at 8.3A or more. Turn on the switch.

Connect Audio: If your system contains a 206e, 207e, or 227e, convenient audio outputs may be located on the back of the case. If provided, these audio outputs are redundant ¼" outputs to the Tini-Jax outputs on the front of those

modules. Connect to your sound system. If you have the ¼” output I/O panel, use the top two connectors for a stereo system. If you don’t have a mixer module like the 206e, 207e, or 227e you can use any signal output. The common output of a 292h would be a good choice. You can use common 3.5mm mono audio cables for your final output, but they may be too loose. For the best audio connections, use the Tini-Plug audio cables that come with the Buchla system and adapt with a module that adapts from Tini-Jax (such as the 202h or 225h).

NOTE: Switchcraft “Tini-Jax” are the standard historical Buchla audio cable connections and are just slightly larger diameter and longer length than 3.5mm connections. They are sometimes referred to as 1/8” in Don Buchla’s manuals, though they are actually .140” diameter connections. Many synth manufacturers now use 3.5mm cables. 3.5mm cables often work in a Tini-Jax jack, but we encourage use of the Tini-Jax/Plug cables as the Buchla standard within a Buchla system. Tini-Jax cables can cause damage to 3.5mm jacks.

Note: e-series and h-series compatibility: While the power supply cable for the e-series and h-series is distinctly different than that in the Buchla e-series, they are compatible and it is expected that e-series and h-series modules will co-exist just as original 200-series and 200e series can coexist. Remote Enable communicates harmoniously on both e-series and h-series.

COMMON BUCHLA SYSTEM STUFF

Before getting into the details of particular modules, lets pursue some items that all 200 modules share in common. First the connections: Like its predecessors--the 200, and 100--the 200e and 200h series differentiates between control voltages, signals, and pulses.

Control voltages (C.V.’s) are used to specify parameter levels, range from 0 to 10 volts, and are interconnected with banana jacks and cords.

Pulses are used for timing information, and have two levels: 10 volt pulses transmit only transient information; while 5 volts carries the sustain information. Pulses, like C.V.’s, also employ banana interconnections.

Signals (audio signals) are the raw material of electronic music, and ultimately become the sounds we actually hear. They are nominally 1 volt in amplitude, but can range from infinitesimally small to 20 db in excess of the nominal. Signals are connected via Tini-Jax connectors and shielded patchcords.

Color-coding of cables and Banana Jacks:

Note that both types of patchcords are color coded to indicate their length-- a handy feature in complex patches.

But more importantly, banana receptacles/jacks are color coded to indicate their function:



C.V. INPUTS are black and sometimes grey.



C.V. OUTPUTS are blue, sometimes violet, and occasionally green (such as velocity on 225's).



Pulse INPUTS are orange*.

Pulse OUTPUTS are invariably red.



(*The Music Easel/208 includes some exceptions to the color-coding standard, particularly for orange.)

remote



enable

REMOTE ENABLE: Saving and retrieving module parameters

Some 200e/h modules contains a switch titled "remote enable".

When a preset manager (e.g. 206e, 225e) is present in the system and the LED associated with the Remote Enable switch is off, the module functions exactly as expected independent of changes to "presets".*

When the Remote Enable LED is on, magical possibilities arise. This is further explained in the 225e description in the 200e User's Guide, but here is a summary:

*In systems without a 225e or 206e, the remote switch will be able to store the current preset, that on turn-on, will be automatically called. Presently, just a few modules include this feature

Blue knobs of the 200e and 200h series can have their settings saved and retrieved when directed by the preset manager. If the LED is off, the module's parameters will not respond to the preset manager messages. (Turning Remote Enable off can be very useful if you want to keep the settings for this module when you change presets, and then with Remote On on again, save in the new preset.) Be aware that when recalling a new preset, the saved knob setting will often not be the same as the current knob setting. But fear not. Turn the knob in the normal fashion, and the value will change in the same direction, eventually catching up with the current knob setting. Switch settings will be stored and LEDs will show the setting accurately. Grey knob settings cannot be stored and will always represent the setting you see.

Ground reference connection:

 On every Buchla boat/housing there is a black banana jack (sometimes labeled “gnd”, often near the card slot. When interconnecting/patching between two synthesizer systems, it is important that the ground reference is shared between the systems--including between two Buchla systems. The ground references should connect here through a banana cable. Without this shared connection, control voltages will have behave unpredictably. The connection is not necessary on an isolated system.

Card Slot:

This card connector is used for both Memory Cards and USB Firmware Cards.

Memory cards--used in conjunction with a preset manager (i.e.225e, 206e)--can be used to store settings of all the modules in a system. Modules store their own preset parameters, but there is a way to store these modules parameter information on the Memory Card so that if your system was stolen or damaged, you could replace the module(s) are rewrite all the saved parameters onto the new module by writing to and from the memory card. See more about this in the preset manager description.

USB Firmware Card: Firmware Updates

To allow improvements in firmware, we’ve come up with a USB card that can upload the various modules with the latest firmware versions.

With the power off, insert the card; then while holding a module’s reset enable switch, turn on the power. **See the website for up-to date instructions for each module.**

These notes are also on the website: Reference Notes about exceptions and what to expect when downloading firmware: 281’s are loaded twice with the same firmware card, depressing the quad enable switches instead of the remote enable switch. Similarly for the 256e, with the breakpoint switches for sections A and C serving to load this unit’s two computers. The 225e is actually two completely separate modules. The top one, the 225M, is loaded as usual, using the remote enable switch; the bottom module, the 225P has no remote switch. Use the data switch instead. Same for the 206e. The 285e has a computer for each section, with the reference select switches choosing the section. This module uses firmware cards 285F and 285B for the two sections. The 223e has two computers; 223A is loaded by holding down the green “clock” button and 223M is loaded with the “remote enable” button.

Wait up to two minutes or until the module’s lights return to their normal state.

Other indications of successful firmware downloading: You will the LED on the USB Firmware card blinking quickly when it is downloading software and any preset manager in a system will suspend it’s operation while the module downloads it’s firmware.

The USB Firmware Card's alternate use is as a USB MIDI to internal MIDI bus interface.

USB MIDI I/O Card (225m):

To Enable this facility, hook up the Firmware Card to a Mac computer and use the Buchla Firmware Utility application to reprogram it's function as a MIDI interface for a 200e or 200h system.

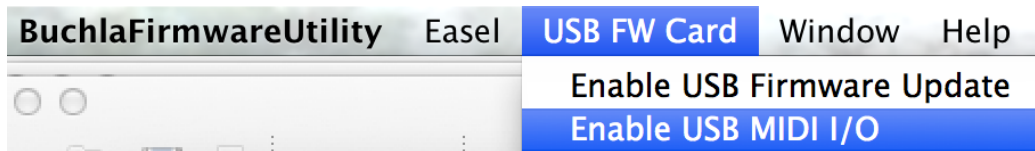

In this mode, the USB device name for the Card becomes "225m".



An example of the device listed in an Ableton "Live" MIDI preferences window.

MIDI note messages sent on channels 1-4 will be put onto the internal busses A-D, as will MIDI clock/start/stop messages and vice-versa. That is, modules that generate messages on the internal bus will also produce USB-MIDI output on the 225m. That includes the 226h or 218e note messages (if enabled) or the 252e clock/start/stop.

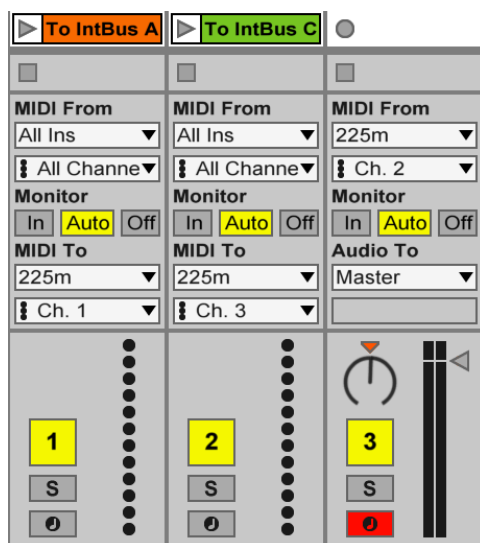

The example to the left shows the card being used to send Ableton MIDI clips to the Internal MIDI bus A and C as well as recording Internal MIDI bus B.

For more information on the internal busses utilized by 200e and 200h modules, please see the 225e section of the 200e User's Guide.

If you loose USB-MIDI Port, use the BuchlaFirmwareUtility to program the card again and you should see the port reappear.

To return a Firmware Card's function to do Firmware Update's, simply use the FirmwareUtility again to Enable/reprogram the card for Firmware Update.

Conclusion and Further Development:

We hope that covers a basic introduction to the unique features of the Buchla systems. We are always looking to expand and improve our designs. So keep in touch.

For descriptions of individual 200e series modules, read the following pages.

The Preset Manager (225e or 206e):

Sharing the same panel on a 225e or 206e, but completely independent of the mixer or the MIDI Interface is a facility dedicated to Managing Presets and to Firmware Updating. First, we'll deal with Managing Presets:

How it works:

Each 200e series module has a built-in processor that can read that module's knob settings and switch positions. On command from the preset manager this data is stored in the module's LOCAL memory and associated with a preset number. That stored data is retrieved and the settings are restored when the module gets a recall command with that preset number.

Even though the modules preset parameters are stored on the module itself, if you have multiple modules--all with remote enabled--they respond as a global preset. A user can store up to 30 presets with each being retrieved by simply transmitting its number to all the modules in a system.

Resolving differences in visible knob settings with recalled patches:

Now obviously, a knob (without a motor) cannot indicate the value of its associated parameter. It has a mechanically (indicated) value, but what we experience sonically is the underlying (virtual) value most recently received from the manager. The dilemma is resolved by persuading the virtual value to "catch up" with the indicated value. When you move a knob, this virtual value will change faster or slower than normal, but in the same direction as you turned the knob, eventually causing the virtual and indicated values to agree. (Some modules implement an earlier version of the knob catcher, doing nothing until the user catches the underlying value. We'll update these.

Switch settings are simpler; LED's show the true status of each switch.

DATA MODE SWITCH:

Press the switch under the word "DATA" to cycle through the various programming modes and displays. Now choose "select".

Select mode: Storing the preset:

Say you found that mouth-watering sound you want to save for posterity (or at least tomorrow's gig). Here's how to save it as a preset:

The first line of the LCD display will contain the current (last recalled) preset number followed by a name (if named). The second line points to a memory location (from 1 to 30). Use the data wheel to select a memory location for your preset---and with the system's modules remotes enabled--press the store button.

If the 206e / 225e's "store" switch is pressed, the current state of modules with remotes enabled will be read into the current memory location. Parameters can then be altered by moving knobs or switches, but this will not alter the underlying stored values until store is pressed again. An LED indicates that the current preset is not stored.

Selecting/Recalling a Preset:

Selecting a preset is equally simple. With remotes enabled, choose a desired preset with the data wheel and hit "recall". The chosen preset will appear in the first line of the display (the "current" preset), and your system will assume the appropriate state.

The switches "last" and "next" can also be used to instantly recall the preset from memory.

Pulse inputs can also be used in this same way. (See "Pulse input modes" in global settings. This can be used to create a chain of presets.

Note: You can selectively decide NOT to store or recall parameters on a particular module by NOT having that module remote enabled. This is very useful when coming up with variations of one preset.

Name mode: Naming the Preset:

Once stored in memory, a preset may be named (or renamed). To name the preset, hit the mode switch, illuminating the "name" LED. Use the "last" and "next" switches to direct the cursor position, and the data wheel to select desired characters. When naming is complete, typically you return to "select". But let's explore the global setting.

Global mode: Global settings and memory card functions

You can use the mode switch to display three displays of that global option that apply to the system. (*This section assumes you have the Primo version of the hardware and software.*)

Global settings: The first global display controls the setting and clearing of the remote status of ALL the modules in a system. The command is sent when the cursor is in the status field and the data wheel is turned. This is a convenient way to change the system status with a single knob. Use the "next" key to cursor to the Disp field and set the LCD contrast contrast for both the preset manager and the MIDI decoder for best viewing.

**Rem Stats: Disp:2
Base Channel: 16**

The next global entry is the base channel. The preset manager responds to MIDI program change messages received on the specified base channel. A blank here disables this response to program changes.

Pulse input modes: Push the mode switch again. You can now choose how the pulse inputs work. The simplest selection is <-Last_Next->. Pulse inputs will act the same as the button press for "last" and "next". If instead you choose <-C.V._Samp-> then the left pulse input acts as a CV input for random access of presets based on the voltage when the left pulse input receives a pulse. (We are overripening the orange banana into functioning like a black banana. Your results may vary. It is recommended to use <-Last_Next-> when possible.)

**<- Last Next ->
Format Card**

Memory card functions:

Formatting a card: A facility exists to store presets on a memory card. If the card is new, it must be formatted, accomplished by inserting it in the memory socket, moving the cursor to "format card" and rotating the data switch. Formatting a card also erases the card, so be careful when formatting cards.

Push the mode switch again: The next entry allows one to move presets or groups of presets. Pick the desired range for the source presets and the desired range for the target.

**16-30 to 1-15
Copy Exchange**

Make your choice, choose “Copy” or “Exchange” , and turn the data wheel.

Backing up your system: By far the simplest procedure to preserve the settings in your systems is to do a full backup of all the parameters in modules and their associated presets Do this by using “Restore from Card” or “Backup to Card”.

<p><u>R</u>estore from crd <u>B</u>ackup to card</p>
--

Why consider a backup of your system’s parameters:

- 1) in unforeseen events leading to theft or damage of a single module or system, you still have a means of recovering your work.
- 2) If you need to firmware reprogram a single module and want to save it’s saved contents before reprogramming.
- 3) If you want to share your awesome sequence with a friend, you can save the contents of your module as yours but in a different system—by backing up your single module and restoring that single module in the other system. Of course this will only work if it’s set to the same module ID (see “The module ID” section below for a description)

Software versions, Module ID’s and Firmware updating.

Reading the software version and module ID: A sustained press on most module’s remote enable switch* will display the module’s current software version on the preset manager’s LCD.

**Exceptions: There are some exceptions to the remote enable switch. One exception is the Preset Manager. Lacking a remote switch, we use the “select“ switch to accomplish the same function. For the 281h Use the quadrature switch. Likewise the 281e – this module has two computers, both requiring the same software. For the upper computer, push the “Quadrature A-B” switch, and for the lower use the “Quadrature C-D” switch. Another special case is the 256e. This module also has two computers executing identical software. Access the top one by pressing the “A” breakpoint switch and the bottom one by pressing the “C” breakpoint switch. The 285e is an exception with 2 computers but with different software– use the reference select switches to select the section you’d like to deal with.*

In addition to the firmware version, this action displays a module’s I.D. (if applicable)

The module ID:

The preset manager and the internal bus communicate with each module independently. Each module knows what kind of module it is and what internal messages to listen for. But we expect multiples of some modules in a system and for those modules there also is a module ID. (Having up to four 261e's are the most obvious example.) The only way to tell these modules apart is with a module ID. It's important for backups to memory cards so modules can be independently identified. The previous section also describes how module ID's are important for assignment on the internal bus. DIP switches on the back of these modules allow a technician to easily change the module ID if it has one. If you bought the module as part of a system, these are set at the factory for you, but it can be altered by the user as necessary. Contact Buchla for instructions.

Note about conflicting/shared module IDs: The parameters of a module are saved with that module and associated with a preset number. Similar modules with shared/conflicting module ID's will not overwrite each others saved parameter if a memory card is not used. And if a crazy and highly unusual system required conflicting module ID's—a system with MORE than 4 oscillators of the same type (e.g. five 259e's) in one system, or any multiples of modules without a module ID—you can still use them independently in a system. But to save the contents of each module on a memory card, but you'd have to turn remote enable off for the conflicting module(s) IDs and use a 2nd memory card.

Also note that some h-series modules like the 292h 281h are simply half of their e-series counterpart (e.g. 292e, 281e) and therefore need unique module IDs if the h-series and e-series versions are together in one system.

Firmware Updating: When to consider reprogramming your module:

Now that you know the software version of your module, you can compare your software to the software versions compiled on the Buchla website. Consider updating your module if you have an older software version.

Or perhaps something has occurred that has caused your module to go haywire.

Updating a module's firmware:

You can find the programs and more complete instructions for downloading and updating a module's firmware on the Buchla website under "downloads". Below is only a summary of what you might expect to perform once you've successfully downloaded your software updates.

Updating a module's firmware involves shutting down the system and inserting the Firmware card. Then, while pressing and holding the target module's remote enable button/switch (or its substitute*), turning on the system power. After two or three seconds, release the switch. The new firmware will be transferred to the selected module. The procedure will take up to two minutes. When finished, the module will assume its initial state. (If you have a 292e, you may see indication of any programming within the system on it' blue LED.) Wait up to two minutes or until the module's lights return to their normal state.

*See *Exceptions to the remote enable are mostly for modules with 2 processors and therefore 2 programming procedures. The same switch that when held displays the module's firmware and module ID also substitutes for the remote enable switch in Firmware updating procedures. One exception: The 225h does not report it's firmware version but firmware can loaded by connecting the input of the gate-to-pulse converter on the upper left of the module to a voltage >2.5v (e.g., the output of the Euro-to-Buchla CV processor on the 225h with the pot offset set to 5v and banana cable from the blue "out" jack to the white banana jack).*

Description - model 206e Mixer section

110427

A dual function module, the top section is a 6 in by 2 out mixer; the bottom section is the Preset Manager.

Mixer

The mixer portion features pan controls for each channel. Channels 1 and 6 are voltage controlled, while channels 2 – 5 are set with dedicated knobs. Note that channel 1 is, by default, directed to the left output; an increasing voltage will move its signal toward the right. Channel 6 behaves similarly, but with reversed response. Gain adjustments are provided for each input channel. Output levels for the left and right output channels are monitored with LED VU meters, with + 10 db levels occurring just prior to clipping.

A headset monitor is also provided. Its level is not stored as part of a preset.

To connect or disconnect this module from the central library function, push the remote switch. The lighted LED signifies a connection..

The 206e settings may be locally stored and subsequently recalled by the Preset Manager, described below.

Sharing the same panel, but completely independent of the mixer is a facility for Managing

Description - model 207e Mixer / Preamplifier

207110427

A dual function module, the top section is a 6 in by 2 out mixer identical to the 206e mixer; the bottom section is a microphone preamplifier, to be described subsequently.

The mixer portion features pan controls for each channel. Channels 1 and 6 are voltage controlled, while channels 2 – 5 are set with dedicated knobs. Note that channel 1 is, by default, directed to the left output; an increasing voltage will move its signal toward the right. Channel 6 behaves similarly, but with reversed response. Gain adjustments are provided for each input channel. Output levels for the left and right output channels are monitored with LED VU meters, with + 10 db levels occurring just prior to clipping.

A headset monitor is also provided. Its level setting is not stored as part of a preset.

The bottom section of the 207e is a preamplifier. Gain is switch selectable, with a sustained press (1 second) toggling the phantom power for all the channels.

An envelope follower with c.v. output is also provided; LED's indicate low, normal and clipping levels.

To connect or disconnect this module from the central library function, push the remote switch. The lighted LED signifies a connection..

The 207e's settings may be locally stored and subsequently recalled by the Preset Manager, a portion of both the 206e and 225e modules.

Description - model 210e Control Voltage and Signal Router 210071215

This module directs the routing of eight control voltages and eight audio signals. The two sections function independently. Originally conceived of as an aid to store and retrieve patch routings, the 210e evolved into a module with additional capabilities.

In the control voltage section, each of five outputs can be connected to any one of eight inputs (the functional replacement for a patchcord). If more than one input is routed to an output, the result is the sum of the applied values.

Similarly, the signal routing section allows connection of each of five outputs to any one of eight inputs (patchcord emulation). Additionally, this section provides the possibility for matrix mixing, in which an output can respond to multiple inputs, with each connection independently scalable.

To route a control voltage, use the lower input/output select switches to choose the desired input and output (crosspoint); use the level knob to establish the degree of connection. A direct, full scale connection is indicated by both LED's being lit. A lesser connection has just one LED on. Note that multiple inputs can be connected to a single output; the output will be the sum of the scaled inputs. A push of the level knob will immediately connect the signal at full level or disconnect it (at no level).

To route an audio signal, use the upper select switches to choose a desired input and output; the amplitude knob selects the desired signal level. Lower than full scale settings are indicated with an orange LED; unity gain and larger with both LED's. A single red LED indicates the maximum amplitude, 10 db more than unity gain. Multiple inputs connected to a single output are mixed (summed). (To emulate a patchcord, select just one input per output and set its amplitude to unity gain.) A push of the knob will immediately connect the signal at full level or disconnect it.

Use the solo switch to audition the effect of a single input; other inputs will be disconnected in this mode. Additionally, the solo switch turns the entire display into an indicator of the coefficients associated with the 5 selected inputs for both the signal and the control voltage inputs. The thresholds for the LED's are .2, 1.6, 3.0, 4.4, 5.8, 7.2, 8.6, and 10.0. Or thereabouts. The display is a multiple bar graph, with all LED's below the set one illuminated. Reset the solo switch to escape this display

Patch routings and level settings may be locally stored and subsequently recalled by the model 225e or 206e preset manager.

To connect or disconnect this module from the central library function, push the remote switch. The lighted LED signifies a connection.

Description - model 218e Touch Activated Voltage Source

The 218e is capacitive keyboard modeled after the original 218 built in 1973, but adding an arpeggiator, fourth preset voltage source, and MIDI capabilities.

First, the keyboard surface and its outputs:

Tactile keyboard Surface

The surface consists of 29 individual keys comprising 2-1/3 octaves. Each touch of the keyboard generates a pulse, a pressure CV, and a main pitch CV. These outputs are placed in the upper left of the 218, expecting to be plugged directly into the nearby the pulse, pressure, and pitch CV inputs of a 208.

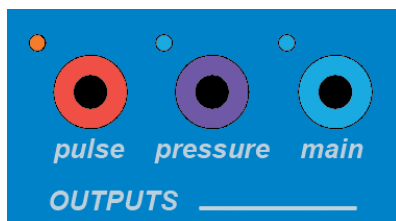

The **pulse** output is red banana on the upper left. A red LED will indicate every pulse output. The **pressure CV** output correlates to the detected amount of finger contact on the keys. The blue LEDs next to the pressure output will get brighter as the voltage gets higher.

The “**main**” output corresponds to the pitch of the key.

At the Buchla standard of 1.2v/per octave, that means that the pitch C will be 0v, 1.2v, 2.4v, 4.8v or 6.0v depending on the octave being played. (Notice how conveniently that relates the MIDI “C” notes 0, 12, 24, 48 and 60.) Every ½ step higher will be .1v higher.



To the right of these outputs is **Portamento** control. Adding portamento will make the pitches slide from one to the next like a violinist sliding a finger to the next pitch. It is an endearing musical affect. To control the speed of the slide, turn the knob higher. At 0, it does not slide; At 10 it may take several seconds to reach the next pitch. The input banana is another way to control this parameter with a CV. The CV input will add to the portamento time set by the knob.

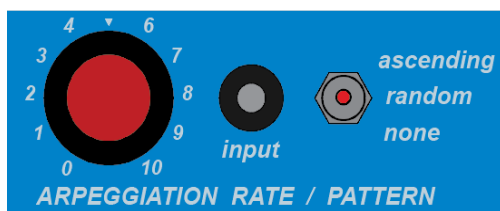

To the right of portamento is the **Arpeggiator**. The 218 will arpeggiate based on the keys that are sustained with the fingers or sustain pedal. The rate can be controlled by the knob or the CV input. The switch determines

whether the arpeggiation is active or whether it plays an ascending or a random pattern.

(Note: pulse outputs during arpeggiation are 10v pulses with sustain, and therefore the voltage drops to 5v and does not drop down to 0v.)

Next is the **PRESET VOLTAGE SOURCE**

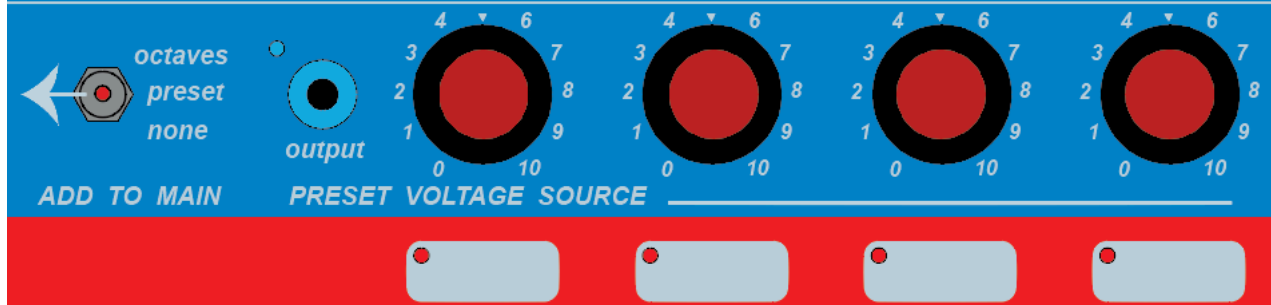

Only one “preset voltage source” can be selected at a time as indicated by the LEDs. The knob above each pad sets the output CV from 0-10v. The corresponding voltage will appear at the blue “**output**” banana when that knob/source is selected.

Additionally, that preset voltage source can affect the “main” pitch CV output per the **ADD TO MAIN switch** setting.

The “**preset**” setting will add the CV--as set by the selected knob--to the main output. But the most common application is to use the “**octaves**” setting for **instant transposition of the main output**. If used in combination with the “output” CV, the user might use the preset output to automatically change a parameter of a sound based on the octave being played.

218e Input and output jacks:

Sustain: The Easel comes with a ¼” connection labeled “(opt. right)/sustain.” the factory jumper setting should be set for the 218e sustain pedal input since the Easel is really just a mono audio output.

MIDI: Use of the 218e for MIDI to CV conversion:

The 218e also converts incoming MIDI signals from the 5pin DIN MIDI IN to CV’s. MIDI notes become pulses and main pitch CV outputs, and channel pressure messages from 0-127 get sent out the pressure output as 0-10v.

All the controls of portamento, arpeggiation, and preset voltage source selection will still apply when using this MIDI input.

The optional 218LEM housing also includes all this plus a 5-pin DIN MIDI output and 3.5mm jack outputs with 1v/octave pitch, 0-8v pressure, and 5v gate and trigger outputs for use with Eurorack equipment.

Additional 218e settings: Configuration mode*

To enter configuration mode, hold the first two preset pads until they both flash twice. (The 4th preset pad LED 4 will start flashing.)

Assigning Internal MIDI bus output (with Preset knob 1):

In this configuration mode, the illumination of the four preset pads indicates the internal MIDI bus assignment. The 218e boots up unassigned. This can be changed by turning preset knob 1 through selections: none, A, B, C, D, A+B, C+D, A+B+C+D. (Note: The AuxCard oscillator listens to internal bus C.)

Velocity adjustment for internal bus and MIDI output of LEM218: Preset knobs 2 and 3 adjust the minimum and maximum velocity values: Knob 2 is the minimum; knob 3 is the maximum. If a constant velocity value is desired, set the minimum higher than the maximum. In other words, If knob 2>3, then the velocity will always be the value set by 2.

Pressure sensitivity is set by preset knob 4.

Exit configuration mode the same way you entered the mode: hold preset pads 1 and 2 until they flash twice.

Note: These settings are temporary. They will not be saved and will require re-setting on the next power cycle.

**Note: If you have an older 218 (without and “e” in the “218e” model number), you may have earlier firmware with only a basic “Adjustment Mode” for pressure sensitivity only.*

For this pre-code loader version of the firmware, the procedure for setting pressure sensitivity is setting all knobs fully clockwise with the two switches in the “none” position when booting up. Then use preset knob 4 to adjust the sensitivity of the keyboard. Changing any of the other knobs or switches will exit that adjustment mode.

Firmware updates:

If you have a 218e and need to reprogram the 218e with a program update, the “code loader” is activated by having all knobs turned clockwise when the system is powered up.

The 222 Kinesthetic Input Port senses a performer's gestures and transforms them into control voltages for subsequent control of 200e systems. Two classes of gesture are sensed – one is the touch of a surface, and the other is the position of the hands in space. The two will be discussed separately, as they are somewhat independent.

Tactile sensor

The tactile surface consists of 27 individual keys, whose responses can be programmed by the user to generate pulses, programmed control voltages, pressure and impact responses. Some keys can respond to the location of a finger along the key, and two are sensitive to 2 dimensions. Two are dedicated to control of the spatial sensors; their function will be described. All keys contain LED's to indicate their status. Programming is accomplished with the aid of an LCD, whose states are changed with a "page" key.

The first page deals with singular pulses:

Puls	1:Ta	2: d
3: u	4:Tc	5:Tg

Use the cursor key to select the desired pulse, the nature of the response you'd like, and the key you'd like to serve as the source. A blank in the first position of the field causes a pulse to be delivered upon touching the key; a T causes a toggled response, with alternate touches reversing its state. The second position selects the actuating key by either turning the data wheel or by simply touching the desired key.

The next page is one of four "radio" pages (named for a scheme for selecting stations on prehistoric car radios).

Radio:6	ky:g	Loc
CV1:334	CV2:999	

Select the desired page with the data entry knob. Cursor into the "ky" field and capitalize it with the data entry knob to display the keys assigned to the current page. Enable desired keys by simply touching them. Disable them with a second touch. To escape from this mode, cursor to the "ky" field and with the data entry knob, decapitalize it.

The next field provides a choice of voltages that will be presented at the green jacks. Select between Loc, Prs, and Imp (location, pressure, Impact).

A control voltage varying between 0 and 9.99 volts will appear at the violet outputs (the decimal point is not displayed). Cursor into this field to change the programmed voltage. The next field allows a second voltage to be

programmed that appears at the blue jacks. Alternatively, the blue jacks may present location – turn the data knob to the extreme left to access location.

The bottom row of jacks provides access to Location, Pressure, or Impact from individual keys. Each output can respond to a single key with Location, Pressure, or Impact. Use the cursor key to select the data field and the data knob to select the data type (L, P, or I) and the key identifier.

The next page allows the display contrast to be adjusted for optimal viewing. Pick a number between 0 and 7.

The 222e can implement polyphony by stealing radio outputs. Page to:

Polyphony off

Use the data entry knob to select from two to four voices. The display will indicate which of the radio outputs have been “stolen” for application to polyphony. These pages will become unavailable for editing, because they will use the parameters from radio output 6. Their outputs will be used to implement polyphony.

The final page allows us to determine the effect of the two small keys located on the upper left and the upper right corners of the keyboard. The status of these keys determines whether the rings are engaged or not.

L:Sustain rev
R:Toggle

The keys can be switched from the toggle to the sustain mode, and thus determine the effect of the rings. If the R (of rev) is capitalized, then the effect of the keys is reversed, with the left key controlling the right ring, and the right controlling the left. All of which brings us to the:

Spatial sensor

222/2

Start by charging up the rings by plugging them into the provided USB wall chargers. The rings will glow red to show they are charging. To power them on, unplug them from the charger and use the switch on the side.

Fasten the rings to your fingers with the Velcro straps, adjusting them as needed for comfort. The red strap identifies the left ring; the green identifies the right (nautical conventions). The rings are conveniently attached to the first knuckles of the index fingers, with the little windows facing away from the body. The buttons at the center are the switches for the rings. They are easily touched with the middle fingers, but other configurations are possible.

The shape of the performance space is sort of a square cone radiating from the square window on the front of the 222 control module. The range is from about 4" to around 5', with a lateral and vertical space proportional to the distance. An orange LED is illuminated whenever a ring is in the field.

Note that the LED's on the control keys must be illuminated for pulses and control voltages to be produced. This is the default value when the 222e powers on

The left – right position of a ring in the field determines the voltage emanating from the horizontal jack on the panel. As a performer moves his hand to the right, this voltage will increase from 0 to 10 volts. Similarly, a vertical movement will increase the voltage at the vertical jack. As you move your hand toward the window, the proximity voltage (purple jacks) will increase to ten volts. Note that the voltages will not change when you exit the cone. Touching the switch will produce a pulse at the red jack, accompanied by illumination of a red LED.

The expected battery holdup time is about two hours. When the battery light stops blinking rapidly, the battery will assuredly decay in less than one hour.

When patching the 200e system, be careful not to occlude the optical path between the sensor and the hands – otherwise the signal will be interrupted unexpectedly.

All parameters (including key maps) may be locally stored and subsequently recalled by the model 225e or 206e preset manager.

To connect or disconnect this module from the central library function, push the remote switch. The lighted LED signifies a connection.

Description - model 223e Tactile Input Port

223110128 1/4

The 223 Tactile Input Port is a mutation of the 222e Kinesthetic Input Port; it drops the ring sensors in favor of a simple arpeggiation function. We'll deal first with the tactile surface and its outputs; then with the arpeggiation.

Tactile Surface

The tactile surface consists of 27 individual keys, each containing an LED for status indication. Responses can be programmed by the user to generate pulses, programmed control voltages, pressure and impact responses. The longer keys can respond to the location of a finger along the key, and the two hexagon keys are sensitive to 2 dimensions. Programming is accomplished with the aid of an LCD, whose states are changed with a "page" key.

The first page deals with singular pulses:

Puls	1:Ta	2: d
3: u	4:Tc	5:Tg

Use the cursor key to select the desired pulse, the nature of the response you'd like, and the key you'd like to serve as the source. A blank in the first position of the field causes a pulse to be delivered upon touching the key; a T causes a toggled response, with alternate touches reversing its state. The second position selects the actuating key by either turning the data wheel or by simply touching the desired key.

OUTPUTS 6 - 9

The next page is one of four "radio" pages (*named for a "radio button" scheme for selecting stations on prehistoric car radios and nothing to do with RF*).

Radio:6	ky:g	Loc
CV1:334	CV2:999	

Select the desired page with the data entry knob. Cursor into the "ky" field and capitalize it with the data entry knob to display the keys assigned to the current page. Enable desired keys by simply touching them. Disable them with a second touch. To escape from this mode, cursor to the "ky" field and with the data entry knob, decapitalize it.

The next field provides a choice of voltages that will be presented at the green jacks. Select between Loc, Prs, and Imp (location, pressure, Impact).

A control voltage varying between 0 and 9.99 volts will appear at the violet outputs (the decimal point is not displayed). Cursor into this field to change the programmed voltage. The next field allows a second voltage to be programmed that appears at the blue jacks. Alternatively, the blue jacks may present location – turn the data knob to the extreme left to access location.

CV OUTS 10-14

The bottom row of jacks provides access to Location, Pressure, or Impact from individual keys. Each output can respond to a single key with Location, Pressure, or Impact. Use the cursor key to select the data field and the data knob to select the data type (L, P, or I) and the key identifier.

HEX KEYS R & S

No programming is needed for the two Hex Keys and they will always respond by default out their respective outputs.

The next page allows the display contrast to be adjusted for optimal viewing. Pick a number between 0 and 7.

The 223e can implement polyphony by stealing radio outputs. Page to:

Polyphony off

Use the data entry knob to select from two to four voices. The display will indicate which of the radio outputs have been “stolen” for application to polyphony. These pages will become unavailable for editing, because they will use the parameters from radio output 6. Their outputs will be used to implement polyphony.

Arpeggiator

An integral part of an arpeggiator is a beat clock. The clock source is selected with the “clock” button. The 223e features three possible clock sources.

- 1) Ext – In this mode the arpeggiator will step with each pulse received in the “pulse” input.
- 2) Int – In this mode the arpeggiator will step based on eighth notes counted by the internal clock. The tempo is set with the “tempo” knob and is continuously variable from 42 to 480 BPM. An applied voltage into the “cv in” input can modulate the clock frequency.
- 3) MIDI – In this mode both clock LED’s are off. The arpeggiator uses the MIDI clock, internally transmitted from the 225e. The tempo knob selects the divide ratio applied to the MIDI clock. The available divisions are:

- a) quarter note
- b) quarter note triplet
- c) eighth note
- d) eighth note triplet
- e) sixteenth note
- f) sixteenth note triplet
- g) thirty-second note
- h) thirty-second note triplet

Each range corresponds with a light on the LED ring around the tempo knob. An applied voltage to the CV input can modulate the division.

It is essential to select the keys to be arpeggiated and to determine the control voltage associated with each key. To select the keys available for arpeggiation, first hit the “page” key ‘till the “ARPEGGIATION” LED is illuminated. The following display will appear:

```

Arpeggio ky: a
CV:0   Tr:1 275
```

Cursor to the letter a. Now play a key that you’d like arpeggiated. Its letter name will appear. Turn the data knob clockwise, thus capitalizing the name. Play each of the keys to be arpeggiated, turning the data wheel after each entry. Turn it counter-clockwise to remove the selected key from the group.

To expediently create a group of keys to be arpeggiated, cursor to the ky field and turn the data wheel clockwise, thus capitalizing KY. Now simply play each key you’d like in the group. Its LED will illuminate. Another tap on the key will remove it from the group and extinguish its LED.

The second line displays the control voltage originated by a selected key. Cursor to the CV and use the data wheel to select a control voltage from 0 to 9.99 volts. Do this for each key in the group. The second field on this line selects one of four transpositions applied to the entire keyboard called Tr:1, Tr:2, Tr:3, and Tr:4. Tuning is accomplished by turning the data wheel to select a voltage which will be added (or subtracted) to the global arpeggiator output.

Arpeggiation pattern

A second display, accessed with another strike of the “page” button, permits selection of one of five patterns:

```

Rising
Fde in:10 out:10
```

There are 5 patterns, displayed on the first line as follows: Rising, Falling, Triangle, Random, and Spiral.

The first three patterns order the selected notes and then play them, ascending, descending, or both, depending on the pattern. The Random pattern employs a pseudo-random number generator, and the Spiral pattern plays notes in a semi-regular pattern, usually playing each note once, before the first is repeated.

The “level” banana output

The second line of the display shows the in and out fade times. Time choices are in seconds and are .5, 1, 2, 3, 4, 6, 8, 10, 15, 20, 25, 30 for both the in and out fields. The fade voltage is a ramp from 0 to 10 volts applied to the “level” output. Typical use of this would be to patch this level output to the velocity input of a 292e dynamics manager. Fade in occurs when the run key is engaged (green); fadeout when unengaged (red). *Note that the arpeggiation pattern and the pulses continue until the fade voltage reaches zero, at which time the run LED is extinguished. So a longer fade time means the arpeggiator will continue run for that time even after it is “stopped”.*

Auto hold/sustain/latch notes on the arpeggiator:

To create and hold an arpeggiation pattern, press the “**add note**” button – its LED will turn green, and the run LED will turn green. Press keys to add them to the arpeggiation pattern. No need to sustain the keys – simply touch them to accumulate a pattern. To delete keys from the pattern, either press and release the delete key, then touch the single key you wish to delete, or hold the delete key, and simultaneously touch each key to be deleted. To ‘lock’ a pattern, press the “**add note**” button again; its LED will turn red. This maintains a pattern while freeing keys for other applications. Pressing the “**add note**” button again will return it to the green (unlocked) mode.

Note that the “R” and “S” keys cannot be enabled for arpeggiation,

Also that the **small hex keys at the top left and right of the keyboard were designed to select the next and previous transpose values. Currently, these small hex keys at the top left and right of the keyboard are used instead to remotely work for the switches for “delete note” and “run/stop.”**

All parameters (including key maps) may be locally stored and subsequently recalled by the model 225e or 206e preset manager.

To connect or disconnect this module from the central library function, push the “**REMOTE ENABLE**” switch. A lighted LED signifies a connection.

Description - model 225e MIDI Decoder

The 225e MIDI decoder translates incoming MIDI messages into analog voltages and pulses. These control signals appear on three kinds of "busses" for subsequent distribution to 200e series modules. Busses A to D are routed internally to 200e series modules that respond directly to MIDI messages. Four more handle only note messages, decoding them into front panel voltages that represent pitches, velocities and pulses with sustain information. An additional six busses handle controller and clock messages (two controllers each), which are translated into standard 0-10 volt control voltages.

Connections: Use the provided MIDI I/O panel and 10pin cable to mount and connect MIDI In. (MIDI Out is not implemented.) See APPENDIX A at the end of this manual for descriptions of alternate ways to connect MIDI In to your 225e.

Busses: Note and Controller message assignments to Pulses and CVs.

Note messages are applied to busses A,B,C,D,E,F,G, and H;

Continuous Controller and Clock messages are handled by busses J, K, L, M, N, and P.

Each bus responds to one selected MIDI channel. But more than one bus may be assigned to the same channel, allowing multiple controllers CVs and note messages to be derived from a single MIDI channel. First select a bus for assignment use "bus select" to illuminate the LED next to the desired bus.

MIDI NoteOn and pitch translation: Busses A-H

There are two sets of Note messages busses: A-D and E-H. Internal busses will be explained in more detail later. For these busses the following display will appear:

Bus:A Ch:15 Poly
Tr:24 Ft:75 Vl: /

With the cursor buttons, select a data type. Use the knob to the right of the cursor buttons to enter data for the following fields:

Ch: MIDI Channel. The first is the channel number; Incoming MIDI messages on the selected MIDI channel 1-16 will be transmitted on this bus. Channel number 0 leaves the bus inactive.

Poly/Mono: (note on) If Mono is selected in this field, then new note messages will cut off the previous notes and new pulses or notes will be generated out the assigned bus. This is the default and best if you have a limited number of oscillators or want to assign each oscillator to a specific MIDI channel. But if you enable polyphony, the bus operates polyphonically between A-D or E-H as notes overlap. In Poly mode, up to four note messages (note on, pitch, and velocity) are distributed between A-D or E-H busses but ONLY IF they are addressed to the same MIDI channel number.

Tr: (or Xpose:) Transpose (pitch). This field causes incoming MIDI note-on messages to be transposed in semitones (chromatically) by as much as + or – 2 octaves. (-24 to +24).

Ft: Fine Tuning (pitch). is for fine tuning. This field is applicable to only internal busses A-D. The number 0 translates to the standard A = 440 Hz. “An” means the fine tuning will be done with the fine tuning knob on the oscillator itself. Numbers 1-99 translate upwards in cents. (FYI 100 cents equals one semitone)

Vl: Velocity. MIDI note messages include velocity information. Normally, this information is sent unaltered, but if desired, non-linear transformations can be applied to velocity. Velocity curves are displayed graphically, with the normal linear response displayed as /, and other responses displayed as slanted or bent lines. Reversed velocity responses are particularly useful for implementing voltage controlled cross-fading.

That covers the display fields. Now to clarify what an internal bus is.

Busses A-D: Internal Busses

The A, B, C, and D busses are dedicated internal busses. All modules within a system share internal communication and some of these modules will respond to note, controller, and clock messages that are appropriate to their function. These modules are the 259e, 261e, 281e, 281h, 292e, 292h 223e, 250e, 251e and 252e. Additionally, the 226h can also send note messages on these busses.

Patching vs internal bus:

Using patch cables on the 225e it is typical to patch noteon pulses using busses E-H (out the red banana jack) to the pulse input of a 281e, pitch CV (out the blue banana jack) to an oscillator, and velocity CV (out the green banana jack) to the velocity input on the 292e.

But you can save your patch cables if you use the internal bus. The internal bus sends noteons to the 281h, velocity to a 292e and accurate pitch information to oscillators such as the 259e or 261e. See below for how to do this.

Assigning the internal bus.

Up to four 259e or 261e Complex Oscillators can be assigned to the four internal MIDI busses A – D. Plus each of the four sections of one 292e Quad Dynamics Manager and one 281e Quad Function Generator can be assigned these A - D busses if their module ID is set to A.

The MIDI messages recognized and potentially routed to appropriate modules on the internal bus include:

- 1) Note On and off messages to 281e/h (if Module ID A)
- 2) Velocity information to the 292e/h (if Module ID A)
- 3) Pitch/Note number information to all 259e's and 261e's according to their module ID. This includes PitchBend Messages.
- 4) MIDI Clock Messages, sent to the 223e, 250e's, 251e, and 252e's

To repeat: the “module ID” used to distinguish multiple modules The oscillators must be assigned to the same bus name (A-D) as the Module ID. The 292e/h and 281e/h must be assigned to Module ID A. (Unlike the oscillators, the 292e and 281e the Module ID is not the same as the Bus name; but instead bus A-D corresponds to the top to bottom on one module.)
To read more about module ID's and how to read them and change them, read “the module ID” section in the preset manager description below.

Controllers: Busses J-P

To select a bus for MIDI Continuous controller information or pitchbend or aftertouch select a buss from the range J - P, the following appears:

Bus:J Channel:15 Cntrlrs:PW:125
--

Busses J has two outputs (a) and (b) corresponding to the two numbers after Cntrlrs: Select between PW (for “PitchWheel”/pitchbend), AFT (for Aftertouch) or Continuous Controller (CC) numbers 0-125.

(Note: Typical preassigned CC numbers found on most keyboard controllers include 1 for Modulation/modwheel, 7 for volume, and 64 for sustain switches)

When using PW keep in mind that pitchbend on channels assigned to busses A - D may be already routed to oscillator modules internally. (See description of internal busses.)

Clock:

If Channel is set to "Clock" (after 16 and before 0) a different interface is displayed:

Bus:J Chan:Clock Div: 1/4 : 3/8
--

The Div fields allow the 225e to generate 10 volt pulses based on rhythmic divisions of an incoming MIDI clock. The numerator represents a count; valid values are 1-8. The denominator represents a note length. Valid values are:

1:	Whole note	8:	Eighth note
2:	Half note	12:	Eighth note triplet
3:	Half note triplet	16:	Sixteenth note
4:	Quarter note	24:	Sixteenth note triplet
6:	Quarter note triplet	32:	Thirty-second note

A pulse is issued after every count of note lengths. In the example above, 1/4 means "every quarter note" and 3/8 means "every third eighth note".

Additional switches:

MIDI Reset button: To restore all voltages and internal parameters to their nominal values, hit "MIDI reset". This also sends "all notes off" and "all controllers off" messages to all channels.

Remote Enable: To enable storage and retrieval of your settings as part of a preset, engage "remote enable".

The MIDI interface's settings may be locally stored and subsequently recalled by the accompanying preset manager.

To connect or disconnect this module from the central library function, push the remote switch. The lighted red LED signifies a connection

225e Preset Manager

*For operation of the Preset Manager on the 225e, please refer back to the **Preset Manager (225e or 206e):** description at the beginning of this manual (page7).*

Model 227e System Interface

This module performs various signal manipulations, prior to sending them to an external sound system.

There are a total of 8 line level signal inputs. Four are primary inputs, and can be individually located in 2 dimensional space under voltage control. The remaining four appear as a separate four channel mixer with a single output; the inputs may optionally be routed to the four outputs. Indicators are provided to display activity and to aid in accurate bus assignment.

First a description of the pots with the grey knobs. Note that the settings of the grey knobs are not stored as part of a preset.

MASTER Equalization and Levels. EQ can be applied to front (A-B) and rear (C-D) channels; a spectral tilt function is introduced that can compensate for the high treble energy frequently characterizing electronic sounds.

Master level pots for front (A-B) and rear (C-D) channels control your main output levels. Monitoring facilities include VU meters on each channel. 1/4 " phone connections on the back of the system parallel the front – mounted 1/8" jacks. The top 2 1/4" jacks are A&B.

Headphones: A switch toggles between the front, rear, or all channels. LED's indicate current status. This setting is not stored.

"Mike preamp": The 227e contains a microphone preamp with envelope detector and level indication. Gain is set in 15db increments with the adjacent switch. The gain is not stored as part of a preset. The microphone connector is an XLR mounted on panel with the 1/4" outputs, usually on the back of the system. (This preamplifier does not provide phantom power.)

Submixer:

A switch toggles the submixer "in the mix" and out of the mix. An LED indicates the status. The all output jack are always active, but using this submixer is an effective way to mix more channels into your final mix if it is in the "in the mix" setting OR as an independent submixer. These pot settings are not stored, but the "in the mix" setting IS stored.

Four signal inputs:

The four signal inputs pots are the blue knobs. Like all blue knobs, their settings can be stored with a preset. But they also have CV inputs and pots for setting "spatial dynamics".

Pot control of location: The left location pots (labeled “rate”) acts as a pan knob. The left location pots have an effective range of from 30% to 70% of their travel.

The right location pot (labeled “amp”) acts to bring control the amount to the front (A-B) or the rear (C-D). The right location pots go from 0 to 30%.

CV control of location: If the pot is turn when turned fully clockwise, these location settings are controlled by the CV inputs at the bananas.

Note that location is determined by either the pot settings or with externally applied voltages – the two modes do not overlap.

Swirl mode:

Toggle the Swirl switch to enable voltage controlled quadraphonic swirling of an applied sound. The associated green LED will indicate the Swirl mode and the meanings of knob settings and applied control voltages will be radically altered.

The left location pots now affects the “**rate**” of rotation of an applied signal, with center resulting in no movement, and extremes resulting in up to 10 Hz rate in a counter-clockwise (pot at min) or clockwise (pot at max) direction.

The right location pots determine the extent of the effect, with 0 resulting in a static, centered sound, and 10 resulting in a sound traveling around the periphery of the listening space.

External control voltages applied when in the swirl mode will add to the pot settings.

Remote Enable

To connect or disconnect this module from the central library function, push the remote switch. The lighted LED signifies a connection..

The 227e’s settings may be locally stored and subsequently recalled by the model 206e or the 225e preset manager.

Model 230e Triple Envelope Tracker

230101013

This module is in two sections. The top section tracks the dynamics of applied signals, and the bottom section amplifies small signals from an external instrument or microphone. The two sections are normally connected internally (“normalled”), but if desired, they can be used independently.

First we’ll describe the workings of the mike preamp, of which there are three. The input connectors accept either Canon XLR’s or standard ¼ inch phone plugs. Three gain ranges are provided, indicated by LED’s, and selected by quick presses of the “gain sets”. The highest (40db) range is usually required for microphones, while instruments will usually thrive with lower gain settings.

Phantom power is available for microphones that require it – switch it on or off by pressing any gain switch and hold for about a second. Phantom power indicated by the green LED is applied simultaneously to all XLR inputs, but never to the ¼” inputs on these jacks.

Individual microphone outputs are provided, as well as a mixed output. An expansion input allows one to use additional modules to expand the inputs.

Envelope Follower: Now for the envelope tracker. The three envelope trackers are normally connected to the three mic preamps. These internal “normalled” connections are indicated by circled “N”’s on the panel. If desired to use an envelope tracker independently, simply patch the its input jack to whatever source you’d like and “normalled” connection will disconnect.

With a signal applied, adjust the “sens” to turn on the orange LED’s; if the gain is such that a c.v. output exceeds 10 volts, a red “overload” light will warn you.

The decay times of the envelope trackers are variable from .1 to 10 seconds.

Pulse outputs: Pulse outputs have two levels in the 200e system. The sustain level is 5 volts, and transients are short 10 volt pulses. Sustained pulses are outputted when the envelope exceeds 5 volts, causing the “action” LED to glow dimly.

The condition for a transient pulse is determined by the state of the “trans” LED. If it is off, transients are generated whenever the sustain threshold is exceeded. If switched on, transient pulses are generated only when a significant c.v. increase occurs, independently of the level. Such pulses cause the “action” LED to flash brightly. Transient signals can thus generate pulses in the presence of background sounds, a particularly useful feature when extracting rhythmic information, as from a drum.

Remote Enable: To connect or disconnect this module from the central library function, push the remote switch. The lighted LED signifies a connection.

Model 249e Dual Arbitrary Function Generator (OBSOLETE) 249050628

The 249e consists of two multi-segment function generators drawing from separate data bases, each with its own clocking and addressing resources.

Data base editing

Organized as two 24 stage circular sequencers, each stage stores the values of two control voltages, two pulses, a time value, and some logic functions. The voltages may be interpolated or modulated with externally applied voltages. The time value can be expressed in seconds, beat fractions, or MIDI clock ticks, and can be scaled by an external voltage. Time values can be scaled separately for each output section. Logic functions include the incrementing of loop counters and conditional jumps.

Editing can be performed while sequencers are progressing. There are green and blue LED's that indicate the current stage that each output is on; when in the edit mode, an additional (green or blue) LED illuminates to indicate the stage number being edited. To enter the edit mode hit *edit*; then use the *stage select* to select a stage number. Hit *edit* again to toggle between the two displays; LED's indicate which display is being edited.

To program a voltage, hit *cv1* or *cv2*; an orange LED indicates that the LCD is displaying the voltage; use the data wheel (upper right of the *EDIT FACILITY*) to set it. Voltage range is from 0 volts to 10.00 volts in increments of .01 volts. Above 10.00 volts are codes that cause the outputs to assume the values of external inputs (ext A, ext B, ext C, ext D). If desired, hit *pitch* to see the voltage displayed as a pitch. Pitch range is 0C to 8F# (octave number + pitch). Resolution is 10 cents. Hit *interp* to interpolate voltages 1, 2, or both. (The output will arrive at the specified value in the time specified by the duration.)

Hit *duration* to set the stage time. The following display appears for either "mult" or "duration". Additional activations of the mult switch toggle between the 3 screens; when mult is active (LED on), the data entry wheel selects the ext source (one, extA, extB, extC, extD) in screen 1 and the tempo in screen 2. The duration switch selects between the two MSD's and the two LSD's in screen 1. The data wheel adjusts the values and scrolls through the note values in screens 2 and 3.

SCREEN 1

Multi	Time	<u>Pulse</u>
extA *	<u>30 .00</u>	sec

SCREEN 2

Multi	Time	<u>SUSTN</u>
Tempo	<u>200</u> *	<u>1 / 16</u>

Tempo is expressed in beats per minute, where 1 beat = a quarter note.

SCREEN 3

Multi	Time	<u>ENABL</u>
Clock	* <u>1 / 16</u>	

Permissible note values are 1/32, 1/24, 1/16, 1/12, 3/32, 1/8, 1/6, 3/16, 1/4, 1/3, 3/8, 1/2, 2/3, 3/4, whol, 3/2, 2.

MIDI clock counts at 96 per 1/4 note are: 12, 16, 24, 32, 36, 48, 64, 72, 96, 128, 144, 192, 256, 288, 384, 576, 768.

The third field, accessed with another strike of the duration key, determines how a start/advance or a strobe pulse will be handled. When a stage has a SUSTN in it, the progression to the following stage is inhibited by an active pulse. With an ENABL, the stage is enabled, and as long as the pulse is active, the sequence will progress normally. Note that either a high start/advance or a high strobe pulse (or both) cause this behavior.

The "option" key provides a short cut for duplicating time information in subsequent stages. Store the current info by holding the key until its LED is illuminated (takes 1 second). Copy it by accessing the desired stage and hitting the key. Exit with the play switch (or an edit select switch).

Hit voltage 1 to get this display:

CV 1	interpolate
<u>10.00</u>	x ext A

Enter a voltage (range 0.00 - 10.00) and a multiplier. The voltage switch advances the cursor between the two LSD's (.00 - .99), the two MSD's (0 - 10) and the multiplier (1, ext A, ext B, ext C, ext D). The multiplier is normalized to one. The "interp" switch toggles the interpolate field (lower case to UPPER case). Similar for voltage 2. Hit "pitch" to toggle to a pitch representation.

Pulses are programmed by toggling the pulse keys. A stage that generates a pulse has an illuminated LED when addressed.

Stops are programmed and displayed in the same fashion. A programmed stop stops the sequence before a jump programmed in that stage is executed.

"loop" sequences the following 3 displays - the first line displays the count:

```
LoopCounter = 67
```

```
LoopCounter = 67
Decrement L.C.
```

```
LoopCounter = 99
Set L.C. = 99
```

"data entry" sets the loop count in the third display

"jump" sequences the following 4 displays and moves the cursor in displays 2 and 3.

```
No Jump
```

```
Jump + 23
Certainty = 100
```

This jumps relative to the current stage #. The probability of executing a jump may be set from 1 – 100.

```
Jump to stage 24
Certainty = 85
```

This jumps to an absolute stage #, with a certainty of 85%.

```
LoopCounter = 99
JmpTo 24 if LC>0
```

Same as above, unless the loop counter =0, in which case it moves to the next stage. Note that loop commands are set on a per stage basis.

Output Sections

Programmed voltages appear at the green or blue banana jacks; their levels are indicated by adjacent LED's. Programmed pulses appear on pulse outputs 1 and 2; an all pulse output occurs for every stage transition.

Time scaling is voltage controllable over a 4:1 range.

Sequencers can be started or stopped with pulses or switch closures. If started already, than pulses or switch closures applied to the start/advance will advance the sequencer to the subsequent stage.

There are three ways to establish the output position of a sequencer. A switch selects one of three addressing schema.

First is x/y, which allows a two dimensional controller to address the sequencer in a continuous circular fashion (with the controls in quadrature).

Next is via a strobe pulse. Pressing the associated switch produces the following display:

Strobe A address
Stage 15

Use the data wheel to select the stage number that a pulse will force. Similarly for the right hand B display:

Strobe B address
Stage 24

The final addressing scheme uses a single voltage to select the stage number. The range and offset may be adjusted up to 24 stages, and the range sensitivity can be multiplied by 10 with the selection switch. This allows an applied voltage of from 0 - 10 volts to scan 24 stages 10 times.

“reset” normalizes the DARF to default values.

250e Arbitrary Function Generator

250110308

The 250e is a 16 stage function generator. Each stage stores two control voltages, which are set with an array of 16 potentiometers. Time values are adjusted with a parallel array of smaller potentiometers, and can serve as a third control voltage. Time can also be synchronized to MIDI clock sent via the 225e. Both control voltages and times can be interpolated, quantized, or replaced with externally applied voltages for selected stages.

Additionally, there are two programmable pulse outputs, as well as a facility for voltage control of stage position. Loop counters associated with each stage can be nested to any level.

Data base editing

Voltages and times can always be edited – just turn the knob associated with each stage to the desired value; to change ranges for either, you must enter the Edit mode, (depress the Edit switch). Turn the center knob to the desired stage, chose the desired time range (one of three) and the voltage range (one of six). Also select the voltage you'd like to operate on (one or two).

Each of the two voltages, as well as the time can be quantized – voltage in .1 volt increments, time in binary rhythmic increments of .01, .02, .04, .08, .16, .32, .64, 1.28, 2.56, 5.12. Time values may be modified through application of an external control voltage scaled from 1/2 to 2. Additional fixed scaling over a range of .25 through 4.0 may be achieved with a dedicated pot. A red quantize LED alerts you that you're very close to the edge of a quantize value. So keep it in the green.

The clock of the 250e can be synchronized to MIDI clock via a 225e. This can be selected on a stage by stage basis by setting the time range to the fourth (blank) value. All modes which require an internal clock to count down (ADV, SUST, ENA) will now wait for an appropriate number of MIDI clock ticks before proceeding. This clock division is set via the small time knob to one of seven values:

- | | |
|---------------------------|-------------------------|
| 1) thirty-second note | 5) eighth note |
| 2) sixteenth note triplet | 6) quarter note triplet |
| 3) sixteenth note | 7) quarter note |
| 4) eighth note triplet | |

If stage 1 is set to use MIDI clock then MIDI start and stop will be obeyed as well. Upon receiving a MIDI start the sequencer will immediately reset to stage 1 for playback. When using MIDI clock the time mult knob and external voltage won't affect the clock division but will affect the interpolation time.

Voltages and times may be derived from external control voltage inputs on a stage by stage basis. Controls for this trick reside in the lower left section. While in the edit mode, select the desired stage number and switch on the time and/or voltage LED's with the associated switches. Be sure to select the desired voltage (1 or 2). The stage pots now change function, choosing which of four inputs to select (follow the scheme of stage 1). A global control ("fix") disables external inputs, storing current values as if they were knob settings.

Pulse outputs are edited on the right side. All stages produce pulses at the "all" output, while pulses 1 and 2 are selected by toggling the associated switches while in the edit mode. Illuminated LED's indicate active pulses.

As an editing convenience, we offer a method of quickly programming identical switch settings in any number of adjacent stages: While in the edit mode, select the value desired for a particular switch, and while still depressing the switch, rotate the edit select through all the stages you'd like programmed to this switch value.

Stage Selection

The 250e offers several schemes for stage selection.

Pulse Mode – This is the default mode for a stage and is indicated when none of the mode LED's are on. A pulse applied to the Start / Adv input or a press of the switch will advance to the next stage.

Advance Mode – This mode is indicated when the "adv" LED is on. The stage will only advance when the time value runs out.

Sustain Mode – This mode is indicated when the "sust" LED is on. The stage will advance when the time value runs out. However, if a gate is applied to the Start / Adv input the stage will pause (sustain). When the gate goes low the stage will continue to run based on its time value.

Enable Mode – This mode is indicated when the "enbl" LED is on. This is the opposite of the Sustain mode; the stage will pause until a gate is applied to the Start / Adv input. At this point the stage will run based on its time value until the gate goes low again.

Stop Mode – This mode is indicated when the "stop" LED is on. This will cause the sequence to stop on the selected stage. A pulse to the Start / Adv input or a press of the button will continue the sequence. Pressing the "stop" button or applying a pulse to the "stop" input will also cause a stage to enter this mode.

In the upper center, we encounter a jump and loop facility, in which the subsequent stage is determined by some programmable logic. While in the edit mode, use the center knob to select a loop's last stage; then hit "set" and

use the center knob to select the loop's first stage. The "jump to" LED's in the bottom of the display will be on here. Hit "set" again to activate the loop counter and dial in the desired loop count. The loop count LED's in the bottom of the display will be on here. Hit "set" to return to the normal edit mode.

A third scheme for stage selection is presented in the lower right section. When in continuous mode, the stage number is determined by the applied control voltage. An offset control establishes the stage number for an input voltage of zero; sensitivity to an applied control voltage is .625 volts per stage. (A full scale excursion of 16 stages corresponds to 10 volts applied control voltage.) When "strobed" is active, the control is sampled, resulting in changes only when a pulse is applied.

Remote Enable

When active, this LED puts the 250e into contact with the preset manager, allowing access to stored preset values.

251e Quad Sequential Voltage Source

251110905

Four independent sequencers, each with a pulse output and control voltage output for each of 99 stages. A separate editing section provides for setting each parameter for a selected sequence; the sequence may proceed while editing a particular stage, or the edit section can track the sequencer, displaying parameters in real time, but disabling edit procedures.

Editing a sequence

To edit a particular sequence, press the sequencer's blue "display/edit" button. The associated LED will ignite, and the stage number it is currently on will appear in the "STAGE EDIT" section. Use "stage #" to select a stage for editing. A press of the *currently selected* "display/edit" switch will terminate the editing mode, the blue LED will commence blinking, and the edit section will display in real time the current parameters as the sequence progresses. *Editing is not possible when in this mode.*

The parameters in the first edit section, "SEQ. EDIT" affect the entire sequence, and not individual stages. (exceptions – "end" & "cycle" are displayed only for the last stage of a sequence, and "sync next" causes the following sequencer to reset to stage 1 whenever it is encountered).

When a number between 6 bpm and 300 bpm appears in the "tempo" field (the usual case), each sequence operates as follows:

Incoming "start" and "stop" pulses control each sequencer's progress. A "stop" pulse stops the sequence at the current stage number. A "start" pulse does one of two things; if there is a value entered for the initial delay, it resets the sequence to stage 1, and starts the sequence after the delay time has expired. If a sequencer has a blank in its initial delay field, then the start pulse merely starts the sequence at the current stage number. A toggle switch performs the same function from the front panel, alternating between green and red LED's, which display the current sequencer mode. When a stop pulse is received, the sequence is stopped.

Other modes besides the internal clock may be used to advance sequences or select their stage numbers. Push the tempo knob to advance through five alternative schemes, all of which assign new and novel functions to the "stop" and "start" pulses:

- b A - “stop” pulses decrement (back) the stage number; “start” pulses Advance it.
- J A - on receipt of a “stop” pulse, the stage number Jumps to the next stage number that contains a “loop begin”; otherwise it jumps to stage 00. “start” pulses Advance it.
- S H - “start” pulses sample the *control voltage* applied to the “stop” pulse; the sampled control voltage is applied to stage selection.
- d i r - a *control voltage* applied to the “stop” pulse is directly applied to stage selection. A ”start” pulse inhibits this activity.
- c l o - “start” and “stop” pulses are ignored. MIDI clock is enabled.

“init delay” delays the sequencer start whenever it receives a start pulse. It does not affect the timing otherwise, being ignored when cycling or looping. The delay is in hundredths of a second, yielding a range from .01 to .99 sec. (Imagine the decimal point).

If nothing is entered in the initial delay (display is dashes), then the start pulse advances the sequence without resetting it.

“reverse” plays the sequence in reverse (retrograde) order. Reverse and sync interact peculiarly. Use them simultaneously at your own risk.

“copy” copies the displayed sequence. With the copy LED on, hit the display/edit button for the sequence that you would like to copy the current sequence to. The copy LED blinks, and the edit section displays the sequence being copied to. Hit “copy” again to complete the copy process.

Similarly for “clear”. With “clear” illuminated, hit the display/edit button for the sequence to be deleted. The “clear” LED blinks; hit it again to complete the transaction. All parameters will be reset to their default values.

To end a sequence, use the yellow button to set an “end” in the stage you’d like to be the last. If desired to repeat the sequence, set “cycle”. Remember that in the cycle mode, “init delay” is ignored.

To use a sequence as a master for the following sequence, set one (or more) “sync next” pulses in the stage(s) you would like the next sequence to start on. Sequence A can thus sync sequence B, and so on, with stage D wrapping around to sync stage A. Synced sequences do honor the initial delay.

In the “STAGE EDIT” section, we set the parameters for individual stages.

First is the interval, entered as a note value from 1/64 to a whole note (1/1). If desired push the button until the 1.5 LED is lit and the displayed note will be dotted (interval multiplied by 1.5). Or push the button again to illuminate “triplt”, causing the interval to assume the time value of a triplet note (interval multiplied by 2/3). If the knob is pressed, a zero interval will be entered, indicating that the stage will be skipped; pressing it again will restore the original interval.

The next display sets the voltage value for the stage, variable from 0.0 to 10 volts, conveniently accommodating oscillators with sensitivity of 1.2 volts per octave. (Each .1 volts adds 1 semitone.)

To achieve a finer control of the 251e’s output voltages, you can set the cents offset from 00 to 99 cents for each stage. This is accomplished by pushing the voltage adjustment knob. The display will *blink*, reminding you that you are setting the number of millivolts to be added to a stage’s output. (A millivolt, if directed to an oscillator with 1.2 volts per octave pitch sensitivity will alter the oscillators pitch by one cent – 1/100 of a half tone.) Push the adjustment knob again to return to the display of volts. *The right decimal point ignites if the output contains a non-zero cents field.*

The next parameter is duration, which determines how long the output pulse lasts, as a proportion of the interval. The choices here are trans, 1/4, 1/2, 3/4, and x1, all representing fractions of the total interval. “trans” selects a pulse with no duration, triggering an attack with no sustain. Durations of 1/4 and 3/4 occur when two adjacent LED’s are illuminated. When all LED’s are off, no pulse appears at the output for the stage being edited.

The next parameter is a loop counter; the LED indicates the first stage in a loop; the numeric 1-9 indicates the last stage as well as the number of loops executed before proceeding to the next stage. In operation, the sequence proceeds until a number is encountered, then jumps back to the first “beg” it encounters. The loop count is decremented each repetition, and on reaching 0, the sequence proceeds and the loop counter is reset to its original value. If the loop number has been set to A, the looping will continue Always, requiring a start pulse to extract you from the infinite loop. Note that if the sequence is running in the reverse mode, the roles of the loop number and the begin stage are reversed.

An additional complexity is the looping of begin points; if a number is inserted in a stage designated as a begin point, then the begin will be honored for that number of loops. When the number is reached, the sequence will jump back to the next loop point, resetting the loop counter to its original value.

The last parameter is the stage number, which is used to select the stage for which information is displayed and edited.

The 251e has the capability of copying information from one stage to other stages. To perform this trick, hit the copy button so its LED is blinking. Now, instead of hitting the “display” button, as we did for copying sequences, hit the switches or turn the knobs associated with the parameters you’d like to copy; the LED’s (or displays) will proceed to blink. Turn the stage number pot to each of the stages you’d like to copy to, depressing it to activate the stage copy. You may hold it depressed while turning it to address contiguous stages. Complete the operation by pressing “copy” again. *Note that when copying a duration value of zero, all three LED’s will blink, and when copying a stage that is neither dotted or a triplet, both LED’s blink, reminding you that this parameter is both zero and primed for copying.*

The Master Clock

All sequencers are driven from a “MASTER CLOCK”. When the bicolor LED is off, displaying neither red nor green, the master clock multiplier is exactly 1, and the tempos for the sequencers will be precisely as indicated. Turning the knob or applying a c.v. to this section will advance or retard this clock, with the maximum advance equal to 1.5 x the indicated tempo and the maximum retardation equal to .5 x the indicated tempo.

All parameters of the 251e can be stored and retrieved as part of a preset. The remote enable light must be on to accomplish this, and either a 225e or 206e preset manager must be present in the system.

Description - model 252e Polyphonic Rhythm Generator

252151029

The 252e sequences pulse patterns and CV values stored in the cells of eleven concentric rings. Ring cells resemble the stages of more conventional sequencers, but the architecture of the 252e allows for interesting and unusual possibilities not previously available. Four pulse outputs and six CV outputs can be assigned freely amongst the cells. Each of the three clocks can be assigned to any of the 11 rings and synchronized to generate two- and three-part polyrhythms and polymetric patterns. Pulses and CVs can be shifted independently within a ring. Pitch and velocity CV pairs can be captured from MIDI input – while editing and during performance. The 252e can synchronize to - or generate - MIDI clock. A Euclidian pattern generator is included to serve as a rhythmic library.

Anatomy

The 252e consists of 5 primary functional areas (roughly clockwise from the top-right):

- CV output and editing
- Display layer selection
- Clock assignment and synchronization
- Cell selection and Euclidian pattern generation
- Pulse editing and output

Quick Start

The default preset is configured with the master clock assigned to the 4 beat ring. There are single Red, Green, and Blue pulses in cells 1, 2, and 3 of the ring respectively. If you press the “play/stop” button, the playhead-cursor will begin to step at the default 120 BPM and you’ll see from the LEDs in the “PULSE OUTPUT” section that pulses are being performed at the expected times.

To alter the BPM setting, turn the “MASTER BPM” knob. The value shown on the segmented display will begin blinking to indicate that you have deviated from the current BPM. To apply the new BPM setting to the master clock, press the encoder down. The value will stop blinking to indicate that the displayed BPM value is now active.

The cells in a ring can only be performed when a clock is assigned to the ring to “drive” it. Clocks are assigned to rings using the clock assign knobs and buttons. The current clock assignment is indicated by an unblinking yellow ring number LED. A pending clock assignment is indicated by a blinking LED.

To change the clock assignment, turn the “assign” knob until the blinking LED moves to the desired ring number. When you press the “assign” button, the LED begins blinking faster and the assignment is changed the next time cell 1 is performed for that ring. Try changing the master clock assignment by turning the “assign” knob and pressing the “assign” button. When the current ring arrives at cell 1, you’ll see the play cursor jump to the new ring you’ve assigned and being travelling around the ring. In the next section you’ll learn how to add pulses to an empty ring.

Basic Cell Editing: Pulses

Press the “edit” button to begin editing cell data. In cell edit mode the “edit” LED will be illuminated and a white blinking edit cursor will appear on the ring display. The edit cursor can be moved around the current ring using the “cell” rotary encoder. To switch rings use the “beats/cycl” encoder. When you switch rings, the encoder’s neighboring segmented display will show the number of cells/beats in the selected ring.

To assign a simple pulse to a cell, select the cell with the edit cursor and **press one of the “red”, “green”, or “blue” pulse buttons**. The selected cell in the ring display will illuminate with the pulse color to show the assignment and the corresponding LED in the “PULSE OUTPUTS” section will also illuminate. Adding more than one pulse to the same cell will mix their colors. Pressing a pulse button a second time will remove the assignment.

Using the “**pulse duration**” knob you can change the length of the pulses in a cell, anywhere from a transient to the entire cell duration at the current BPM. The “**behind/ahead**” knob will cause the cell to be performed late or early relative to the cell’s position in the sequence.

The “cell subdivide” section lets you add up to 7 pulses that will be performed **during the course of the cell’s duration**. The button increments the number of pulses to perform, and knob **distributes them in time**. Zero is an equal time distribution; larger values group the pulses closer and closer together and push them further and further towards the end of the cell’s time domain. Cell subdivide pulses always appear at the “sub-div” jack in the “PULSE OUTPUTS” section.

The “**phase**” knob rotates cell data in the ring forwards or backwards by single cell increments. See the *Ring Display Modes* section below for details about how data is rotated.

Copy, Paste, Clear, and Pulse Fill

When a cell is selected, pressing the “**copy**” button copies all of the cell’s associated data: pulses, pulse timing, and CV assignments (which will be discussed next).

As you might expect, the “**paste**” button replaces the currently selected cell’s data with whatever was most recently copied. If you **hold down the “paste” button and turn the “cell” rotary encoder**, the paste will be repeated into each successive cell. See the *Ring Display Modes* section below for details about how data is pasted.

The “**clear**” button will erase all cell data from the currently selected cell. If you **hold the “clear” button and turn the “cell” encoder**, the erasure will be repeated in each cell. See the *Ring Display Modes* section below for details about how data is cleared.

As a convenience when editing pulses, you may **hold down** one or more of the **R/G/B buttons** and **turn the “cell” encoder to fill** adjacent cells with pulses.

And even more convenient way to quickly fill a circle with pulses, is to generate pulses that create patterns based on “Euclidian Rhythms.”

Euclidian Rhythms

The Euclidean rhythm in music was discovered by Godfried Toussaint in 2004 and is described in detail in the 2005 paper "The Euclidean Algorithm Generates Traditional Musical Rhythms". The greatest common divisor of two numbers is used rhythmically giving the number of beats and silences, generating almost all of the most important World Music rhythms (except Indian additive rhythms).

To generate pulse patterns using the Euclidian algorithm, select a ring using the "beats/cycl" encoder, and press the "RHYTHM SELECT" button to select "Euclidian". **NOTE: this is a destructive operation**, any pulse data in the selected ring will be erased and replaced by the Euclidian solution rendered in red pulses (however, other pulses can be added, see the *Advanced Editing* section below).

To add pulses colors other than red, hold the green or blue buttons while selecting the pattern#.

Turn the "pattern #" encoder to generate each of the Euclidian pulse patterns for the number of beats in the selected ring. The number of pulses in the current solution will be shown on the segmented display to the left of the encoder.

To exit Euclidian mode, press the "RHYTHM SELECT" button, or turn the "beats/cycl" encoder to select a different ring. (Note: editing other parameters is not possible while in Euclidian mode, so to avoid confusion, the 252e automatically reselects the "user-defined" edit mode.)

But the 252e is more than a pulse generator. All these cells can be associated with control voltages to be used pitches, timbres or, of course, dynamics.

Editing CVs

To associate a CV value with a cell, select the cell using the "cell" and "beats/cycl" encoders as described in the *Pulses* section above. Next **press the "select" button in the "CV EDIT" section until the desired CV output is selected. Turn the encoder below the "select" button to assign a CV value.** A fine tune mode is available by pressing the encoder down; press again to return to coarse CV edit mode. (Note: Typical Buchla oscillators are based on a 1.2v per octave range, so .1v would equals a half-step.)

Up to six CV outputs (each with different values) can be assigned to any one cell. Remember that the outputs are shared, so if you assign the same CV output to 2 or more cells that are performed on different rings by different clocks at the same time, the result will be undefined.

The special "none" CV value, indicated on the segmented display by "- -" means "don't change the output CV". For example, if you have 4 beat pattern but only want two alternating pitches using CV output 1, you can assign CV values to cells 1 and 3, and leave cells 2 and 4 with the "none" value. The output value when cell 1 is performed will remain unchanged by the "none" value in cell 2, then cell 3 will change the output value, and cell 4 will again leave it unchanged.

Because traditional sequencers tend to operate with an assumed concept of a “note”, it’s important to emphasize here that there is no inherent relationship between pulses and CVs in the 252e. They can be assigned or not as you like. Cells can have pulses but no CVs, or CVs but no pulses. As you’ll see below, CVs and pulses are both represented in the ring display as R/G/B colors, but that doesn’t imply a functional relationship. For example, you **can** create a single synth “voice” using the 252e where the Red pulse is the note on trigger, CV 1 is pitch, and CV 4 is velocity. We have made it convenient to organize the outputs this way because it’s an obvious application when creating three voice polyrhythms using three rings at the same time. However many other logical organizations are possible and encouraged.

Ring Display Modes

The ring display at the center of the 252e can show four different sets of cell properties using the R/G/B color scheme. At power on time, the “pulses” view is displayed. It might be helpful conceptually to think of the different views as layers, analogous to visual layers in programs like Adobe Photoshop. The “pulses” layer indicates the presence of pulses in cells with the colors red, green, and blue (and their simple combinations). The “cv 1-3” layer shows the presence of CV assignments for outputs 1, 2 and 3 using the same R/G/B scheme. The “cv 4-6” and “subdiv” layers show CV outputs 4,5 and 6 as R/G/B, and cell subdivide pulses as Red. A fifth mode shows them all superimposed so you can see which cells are empty and which are occupied.

Having different display layers helps one to visualize where the various kinds of cell data has been assigned in the rings, but it also affects certain editing procedures. The “paste”, “clear”, and “phase” controls affect only the data associated with the current display layer. So for example, if you press the “clear” button when the “subdiv” display mode is active, only the cell subdivide pulses will be erased from the current cell. Similarly with the other controls and display modes. If you want to duplicate only the CV data for outputs 1, 2 and 3 from one ring into another, you can copy and paste while the “cv 1-3” is active. In fact, **copy always copies the data from all layers, it is the paste function that’s selective.**

This feature adds some complexity to the user interface of the 252e which may make things a little bit confusing for new users, but after a little bit of practice, its utility when editing and performing with complex arrangements will become apparent.

Let’s suppose you choose to associate pulses and CVs together to describe a set of three traditional synth voices. In this scheme, the red, green, and blue pulse outputs would represent note on triggers; red for voice 1, green for voice 2, and blue for voice 3. CV outputs 1, 2, and 3 would represent pitch, and CV outputs 4, 5, and 6 would represent note velocity. A simple application would be to use three different rings, perhaps ring 4 containing only red pulses, ring 7 containing only green pulses, and ring 16 containing only blue pulses. Next you would enter pitch data for ring 4 by adding CV values for output 1; then pitch data for ring 7 using CV output 2; and finally pitch data on ring 16 using CV output 3. Then for velocity on ring 4 use CV output 4; ring 7 velocity on CV output 5, and velocity on ring 16 using CV output 6. This gives you three kinds of data on three different display/edit layers.

Using the display modes, you can now modify and shift the temporal relationships between rhythm, pitch, and velocity independently. For example, with the “pulses” layer selected, turning the “phase” knob will shift the rhythmic pattern in relationship to the pitch and velocity data. When combined with the “randomize” feature described below in the *Advanced Editing* section, you can very quickly create musically expressive patterns and vary them in many interesting ways.

Advanced Editing: Copying and pasting ranges

To select a range of cells for copying, press and hold the “cell” encoder while turning it.

After copying a range of selected cells, the paste operation will differ depending on whether you turned the “cell” knob clockwise or anti-clockwise when you selected the range: the pasted data will appear either forward from the current cursor, or backwards from it. Performing a few experiments will make this relationship more clear.

The “red”, “green”, and “blue” buttons can be used as modifiers to apply editing operations to subsets of cell data. For example, if you are in the “pulses” display mode, hold down the “red” button and turn the “cell” encoder to fill cells with red pulses. To clear the red pulses from the ring, hold the “red” button and “clear” and turn the “cell” encoder to remove only the red pulse from each cell. The R/G/B buttons can be combined in any manner.

This same technique applies to CVs. In “cv 1-3” mode, holding down the “green” button and pressing “clear” will remove any CV data for output 2 in the currently selected cell. To clear the entire ring, hold “clear” and turn the “cell” encoder.

The R/G/B modifier buttons applies as well to the “phase” encoder and “paste” button, enabling selective transformations within a display layer.

Advanced Editing: Randomize

An extension of the R/G/B button-as-modifier technique provides a randomize function. In the “pulses” display mode, **holding down the “blue” button and pressing the “edit” button** will fill the currently selected ring with a random pattern of blue pulses. This function also applies to CV values and cell subdivide pulses.

Advanced Editing: MIDI Capture to CV

Control voltage values can be captured and entered using MIDI note input received on the internal MIDI bus. To enable this mode, make sure you are playing notes on the internal bus. Then in cell edit mode, **press and hold the “CV EDIT” encoder.** The display will change to “i n” and both the LEDs for CV outputs 1 and 4 will illuminate. **In this mode, the CV outputs are considered to be pitch/velocity pairs** (1/4, 2/5, 3/6) and pressing select will cycle through the pairs. A MIDI note received on any channel will trigger a MIDI to CV value conversion where the note number and velocity are converted to CV range and stored in the currently selected cell’s selected CV output pair.

Values can be entered manually by turning the “cell” encoder to select successive cells in the ring and then sending a MIDI note to capture the data. If you **hold down the “cell” encoder, each MIDI note on also advances the current cell** selection by one, so you can fill an entire ring with pitches by playing notes in sequence.

Clock Assignment

Clock assignments can be programmed using CVs and pulses. The **CV input next to the “assign” knob selects the ring, and a pulse at the pulse input next to the “assign” button starts the assignment.** Note that the assignment is not fixed when the button is pressed (or pulse received), so if you turn the knob or change the CV before cell 1 is reached on the ring currently assigned to the clock, a different ring will be assigned than the one that was originally selected.

Synchronization

Press the “sync” button to change the clock synchronization method.

Sync mode **“on 1”** means that **cell 1 of all active rings will happen at the same time.** The master clock will run at the indicated BPM, and clocks two and three will drive their assigned rings at whatever rate is necessary to get the ring to cell 1 on time.

Sync mode **“on cycl”** means that **all cells will advance at the same rate.**

If neither sync LED is illuminated, the clocks are not synced. In this mode you can press and hold the “assign / Δ t” button for a clock to enable its time scaling mode. In this mode, the green LED is illuminated and the clock knob will scale the master BPM, from .5x – 3x, as does the knob’s associated CV input.

Pressing the “reset” button will force all active rings to resync at cell 1.

MIDI CLOCK

The 252e supports MIDI clock sync receive and transmit. This is sent over the internal bus. To enable these modes, press and hold the “MASTER BPM” encoder. The display will change to “oFF”. Turning the encoder selects “S rc” for “sync receive”, and “S tr” for “sync transmit”.

Receiving: You can use external MIDI gear to send messages to the 252e through a 225e or through the FirmwareCard in USB MIDI I/O mode (225m) See the USB Firmware Card description at the beginning of this manual.

To transmit to MIDI Clock messages from the 252e to USB-MIDI, you can also use the Card.

Recalling and Saving Presets without a preset manager

Combining the 252e with a preset manager is the recommended way to name, save and develop your sequences and rhythms. It is not uncommon to develop a set of patterns and make variations that can be recalled with a preset change.

But for users who have a small system with no preset manager, presets can be called up with MIDI preset commands that are sent over the internal MIDI bus using the FirmwareCard’s USB MIDI I/O feature (called 225m) or the 225h. Patches are saved into that preset location by pressing the remote enable button. The LED will then go out.

Quad Control Voltage Processor model 256e

25609030

This module offers various sorts of control voltage processing, including selection, multiplication, addition, scaling, inversion, and non-linear transformation. Its four sections are identical and independent. A description of section A follows, and is applicable to sections B, C, and D.

The leftmost knob selects between two input voltages, A1 and A2 . To enable voltage control of the selection, crank the knob to 0 and apply a selection voltage to “In Select”. A voltage applied to “In Select” replaces the knob, performing the following operation:

$$V_{in} = \text{InSel} \times A2 + (1 - \text{InSel}) \times A1$$

Where V_{in} is the voltage applied to the transformation matrix. For the purposes of the present discussion, the ranges of all input voltages and knob settings are normalized to one. Note that if A1 is unconnected, the input section simply multiplies InSel and A2.

V_{in} is now applied to the transformation matrix, which works as follows:

With no breakpoint specified, 2 LED's will be illuminated, one on the left; the other on the right of the display. A press of the switch adds a single breakpoint, indicated by a third LED somewhere in the display's center.

With the breakpoint switched off, the following function is executed:

$$V_{out} = V_{in} \times V_{10volts} + (1 - V_{in}) \times V_{0volts}$$

This is a simple linear transformation of the input voltage. For zero volts input, the output is set by the knob labeled 0 volts in, and for 10 volts input, by the knob labeled 10 volts in. Other values are interpolated, and the transfer function can be represented as a straight line connecting the two endpoints. The two breakpoint knobs are not operative in this mode.

Now hit the breakpoint switch, and things get more interesting. A breakpoint LED is illuminated whose location can be set with the two knobs to the right of the switch. The resultant transfer function is the two segment line connecting the three points, mathematically represented as:

If $V_{in} < V_{inbp}$,

$$V_{out} = (V_{in} \times V_{outbp}) / V_{inbp} + (1 - V_{in} / V_{inbp}) V_{0volts}$$

If $V_{in} > V_{inbp}$,

$$V_{out} = [(V_{in} - V_{inbp}) V_{10volts} + (1 - V_{in}) V_{outbp}] / (1 - V_{inbp})$$

Sorry that the algebra looks so messy for such a basically simple process. Perhaps a couple of pictorial examples will clarify things for the non-mathematically inclined.

The first example is complete transparency – the 256 does nothing to the applied voltage, and the output is a replica of the input:

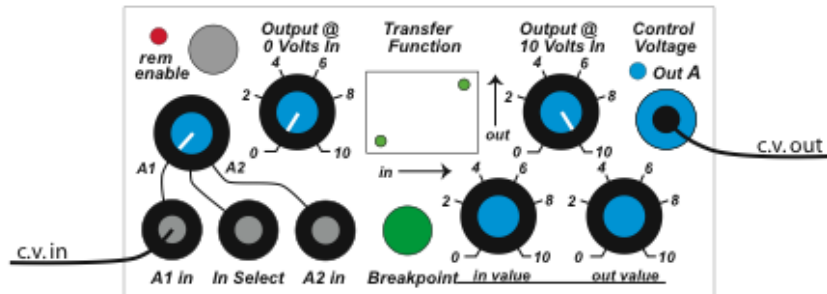

Next we take the product of two applied voltages, and invert the result:

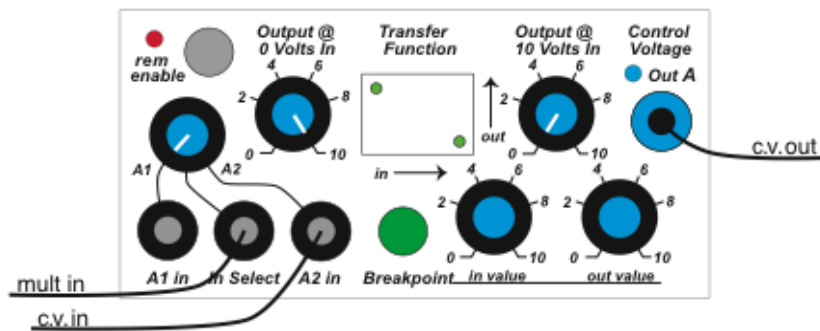

Now add a break point, such that the output stays at a constant 2 volts until the average of two inputs exceeds 8 volts – then the output voltage rapidly goes to 10 volts:

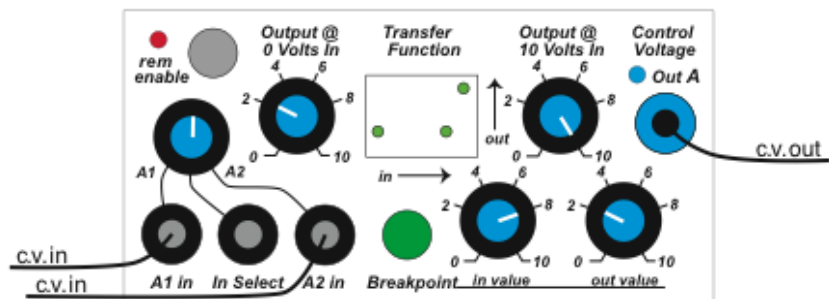

Here we use a voltage to control the proportions of two inputs that are applied to the transform matrix. The output starts at 8 volts, for an applied input of 0 volts, has a negative peak of 0 volts when the input reaches 2 volts, and then goes to 10 volts as the input reaches 10 volts:

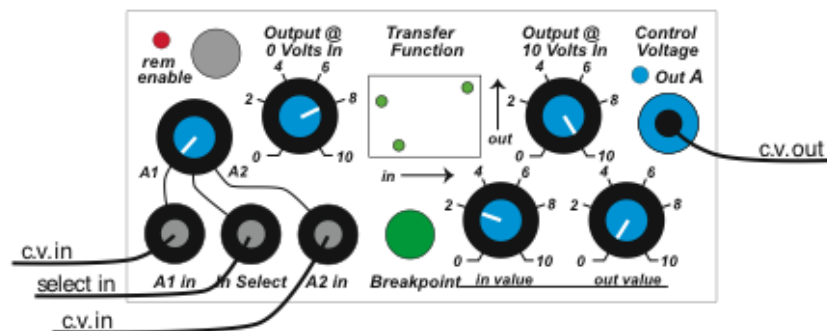

Note that the low resolution display provides a rough but useful indication of the transfer function. The actual voltages are calculated to a high degree of precision, and are appropriate for application to pitch and other variables.

Switch status and pot settings of the 256e can be locally stored and subsequently recalled by the model 225e preset manager.

To connect or disconnect this module from the central library function, push the remote switch. A lighted LED signifies a connection.

Note that this module has two computers; when downloading or checking firmware, use the breakpoint switches A and C instead of the remote enable switch.

Control Voltage Processor model 257e

The 257e is a control voltage processor similar to the 256e module but unto a world of its own. As its name says this is a CV processor. The A and B section function similarly to 256e but that is where the similarities end. (See the 256e guide above for Sections A & B)

Section C to H:

Sections C through H are for adjusting the slew rate of the input CV signal both negative and positive slew rate and time adjustments.

The inputs and outputs are independent, but the slew control parameters are shared in pairs.

The red bananas are the pulse outputs as always, the blue bananas are the slewed CV outputs. Next to the red banana are two LEDs. The red LED will light with every pulse output. The blue LED will show the CV output.

Slew rate knobs:

The Negative slew rate affects the speed of the negative going CV, and positive slew affects positive going CV. The controls allow for a slew rate of .01 to 10 seconds.

Example: If you put a square wave into the CV input and turn the negative slew and positive slew knobs to matching positions you can turn that CV input from a square wave to a sine wave. Or with that square wave in the CV input, by turning one knob all the way down and turning up the other knob you will get something more like a sawtooth wave.

Note: You can never get a true sawtooth or square wave output since the slew rate does not go to 0. It will always have some slew.

The Grey banana inputs control the slewing parameter just like the knob by to adding to the virtual knob position with it's CV input. (Note: If you have the knob turned all the way to the right, the CV input will have no affect. Turn the knob all the way left for the most control.)

Rate/Time/Auto-Pulse enable switch:

By changing the slew based on "rate" or "time" you will get slightly different behavior. Selecting "Rate" will usually give you a larger CV output range when the input is faster as it tries to catch up to the input rate. "Time" selection slews simply slews based on the time it takes for a voltage to go from 0-10v and can result in smoother slew.

Auto-Pulse enable:

If you press and HOLD down that same selection switch for 2 seconds, the red LED will light to indicate you have enabled auto-pulsing. In this mode a **pulse will be sent every time the OUTPUT CV reverses direction.**

To disable auto-pulsing, HOLD the switch down for another 2 seconds

Note: to get a consistent pulse output based on the **input** CV direction reversal, turn the slew rate knobs down so that slew has minimal effect. Auto-pulse may be less reliable if the slew rates are long, or above 35Hz, or if the range of the input is limited.

Model 259e Twisted Waveform Generator

259091109

The 259e consists of two separate oscillators. One, the *modulation* oscillator, serves primarily to modulate the second, called the *principal* oscillator.

The Modulation Oscillator

The modulation oscillator has two ranges, one in the audio region of 27 to 7040 Hz; the other mostly in the sub-audio, ranging from .25 Hz to 64 Hz. Three classic wave-shapes can be selected (just one at a time), and three modulation targets can be chosen, singly or in any combination.

An F.M. input provides for frequency modulation.

Pitch tracking, when enabled, forces synchronicity with the principal oscillator. With no control voltage applied to the modulation oscillator, its pitch will track that of the principal oscillator. The offset will be zero when the modulation frequency is set to 440 Hz., indicated by an extinguished bicolor LED.

A **sync** facility permits synchronization to MIDI note-on messages, or to subdivisions of the principal oscillator. Hard sync truncates the waveform; soft sync uses a phase locked loop to achieve synchronization.

The Principal Oscillator

The principal oscillator generates a sine wave varying in frequency from 27 to 7040 Hz. The frequency can be modulated with an externally applied signal. This sine wave is simultaneously applied to two wave-shape tables.

Selecting waveshape tables:

The selected tables are indicated with green and red LED's; changes are made with a switch that advances the selection. Short activations advance the selected tables. Pressing and holding the switch more than 1 second toggles between selecting the green and red tables.

“Memory bank” tables--a,b, and c--are actually not tables in the classical sense – they are simply portions of the operating program, full of unpredictable noise and frequent silences. (This memory is volatile, so it will be different the next time you boot up.)

When these tables are invoked, the F.M. controls labeled “mem skew” are re-assigned to table scanning functions and the F.M. inputs become table modulators. This state is indicated on some units by illuminated LED's located above the F.M. controls.

A *morph* voltage pans between the two tables and a *warp* voltage varies the amplitude of the sinusoidal (driving) waveform. Both these functions can be modulated by the modulation oscillator.

Internal Bus messages and Remote Enable:

MIDI messages can be received by the 259e via 1 of 4 internal busses if the module is remote enabled.

A module decodes the pitch (key #) contained in note-on messages originated by a 225e, 226h, or 218e arriving on its bus. It also responds to pitch bend messages.

Storing knob settings is also made possible when the module is remote enabled. As in all 200e series modules, the settings of pots and switches can be locally stored and subsequently recalled by the preset manager such as models 225e or 206e.

To connect or disconnect the module from this central library function, push the remote enable switch. A red LED signifies a connection.

The Internal Bus I.D. for the module is set with two DIP switches on the back of the module, and can be displayed on the 225e by holding the remote enable switch closed for about two seconds. Settings can be for A,B,C, or D. Change the DIP switch settings, reboot and hold remote enable to display your changes. It is most useful if each oscillator in a system has its own Internal Bus I.D.

Potentiometer Calibration:

Generally unneeded, there is a calibration procedure for the input potentiometers on the 259e. It eliminates the slight dependency of frequency versus knob setting for both the f.m. modulation knobs and the c.v. multiplier knobs.

In other words, if you think your multiplier knobs may not be tracking correctly, you can invoke this factory calibration procedure and it may fix the problem.

- Turn all knobs counter clock-wise (CCW) – except *principal OSC* set to 220.
- Hold ‘midi sync’ button whilst you power on boat.
- Hold for 5 seconds and then release.
- There should be a constant tone generating from the 259e. After a few seconds there will be a brief drop in the sound from the tone; this means calibration has been successful.

Fun fact about 259e Revisions:

Revision 4 and below were called the *259e Complex Waveform Generator*: tables 6, 7 and 8 were not memory bank tables.

Revision 5 and above introduced the “memory bank” wavetables.

In Don’s words: “The Twisted version introduces some radically weird timbres. It is definitely not recommended for those over 25 years of age or for anyone with golden ears.”

Model 260e Barber Pole Module

26005010

Now just what is a "barber pole" module? A barber pole, used in a bygone era to identify haircutting saloons, is a spiral (resembles a candy cane) that slowly turns around a vertical axis. The actual movement is rotational and horizontal; the perceived movement is vertical, but illusory. The term has been applied to processes in which movement is perceived to occur continuously in one direction, but ultimately there is no net movement (in that direction). The barber pole stems from another service offered by barbers – that of using leeches to suck blood from clients. The blood-soaked rags were laid out in the sun to dry, and the pole is an abstract reminder of the resultant bloody mess.

The term "barber pole" refers to an auditory illusion that can be readily produced by this module. Called the Shepard tone paradox (after its inventor, Roger Shepard), one's perception is that each note in a forever ongoing series of notes is higher in pitch than the preceding note. The illusion works in reverse also, with each note perceived to be pitched lower than its predecessor. M. C. Escher's "Ascending and Descending" is occasionally cited as a visual equivalent of the auditory paradox.

Model 260e Duophonic Pitch Class Generator

Two independent, voltage controlled pitch class generators. (A pitch class generator produces a singular pitch in every perceivable octave.) Frequency modulation inputs and a five band spectrum-shaping facility are provided.

When switched to the "barber pole" mode, an internal computer takes over pitch control of both generators, and issues pulses for triggering an external envelope generator (like a model 281e function generator), which in turn can drive a voltage controlled amplifier (like a model 292e dynamics manager). When the 260e's output signals are gated through the latter, Sheppard tones and other auditory illusions (such as the tri-tone paradox) may be produced. In this mode, only the left f.m. input is active, affecting both oscillator sections. When switched to the "continuous" mode, the right oscillator descends while the left ascends (or visa versa). The rate of change is variable to 2.5 octaves per second in either direction, and is voltage controllable. Additionally, the pitch intervals can be adjusted from quarter-tones to tri-tones.

With its multi-voicing, equalization, and frequency modulation capabilities, you will find the 260e musically more interesting than the standard Shepard tone generator used in perceptual psychology experiments.

Settings of all pots and switches can be locally stored and subsequently recalled by the model 225e or 206e preset manager.

To connect or disconnect this module from the central library function, push the remote switch. A lighted red LED signifies a connection.

Model 261e Complex Waveform Generator

261090804

The 261e consists of two separate oscillators. One, the modulation oscillator, serves primarily to modulate the second, called the principal oscillator. We'll discuss the two oscillators separately.

Modulation Oscillator

The modulation oscillator has two ranges, one in the audio range of 27 to 7040 Hz; the other mostly in the sub-audio, ranging from .25 Hz to 64 Hz. Pitches may be voltage controlled, with variable magnitude and direction. With the multiply knobs set fully clockwise, stretch tuning may be applied as desired (adjustment holes are below to the right of the main tuning knobs).

An F.M. input provides for frequency modulation.

Waveshape is voltage controllable, ranging from sine through square and pulse; a multiplying input varies the degree and direction. Three modulation targets can be chosen, singly or in any combination. Note that *pitch modulation responds only to sinewaves*.

Pitch tracking, when enabled, forces synchronicity with the principal oscillator. With no control voltage applied to the modulation oscillator, its pitch will precisely track that of the principal oscillator. The offset will be zero when the modulation frequency is set to 440 Hz. (indicated by extinguishing the bicolor LED).

A sync facility permits synchronization to MIDI note-on messages, or to subdivisions of the principal oscillator. Hard sync truncates the waveform; soft sync uses a phase locked loop to achieve synchronization.

Principal Oscillator

The principal oscillator generates a sine wave varying in frequency from 27 to 7040 Hz, which is then applied to three voltage-controlled timbre-shaping elements. The *degree* of timbre is variable in offset, magnitude and direction. *Symmetry* and *order* have variable offset and are voltage controllable.

MIDI messages can be received by the 259e via 1 of 4 internal busses. Bus I.D. for the module is set with two board mounted switches, and can be displayed on the 225e by holding the remote enable switch closed for about two seconds. The normal settings start at A and go for as many modules as you have (up to D, or four).

A module decodes the pitch (key #) contained in note-on messages originated by the 225e and arriving on its bus. It also responds to pitch bend messages and to may respond to fine tuning messages as follows:

To respond to MIDI fine tuning messages, the “Ft” field in the 225e’s display must contain something other than a default value of “An” for the bus of interest (buses A – D). This fine tune data is in cents (a cent is 1% of a semi-tone), and can range from –49 cents to +49 cents. It can be set for each bus, and therefore for each of four oscillators.

Note that if fine tuning is enabled for a particular oscillator, that oscillator’s pitch knob will be incapacitated, as will its F.M. input and control voltage input. Pitch will be completely determined by MIDI signals.

So when you wonder why your oscillators tuning controls seem dead, check the 225e’s fine tuning field for the bus that’s driving your oscillator. You need an “An” in that field to enable analog control.

As in all 200e series modules, the settings of pots and switches can be locally stored and subsequently recalled by the model 225e or 206e preset manager.

To connect or disconnect this module from the central library function, push the remote switch. A lighted red LED signifies a connection.

(Generally unneeded is a trim procedure for the input potentiometers on the 261e. It eliminates the slight dependency of frequency versus knob setting for both the f.m. modulation knobs and the c.v. multiplier knobs. To invoke this procedure, turn all four knobs to their maximum counterclockwise positions, then press and hold the sync button for about 5 seconds.)

Model 266e Source of Uncertainty

266090312

Fluctuating Random Voltages

Two independent sections, A and B, generate continuously changing random voltages with voltage controlled “probable rate of change”.

Quantized random voltages

This has two sections, called C and D, that share the shape and number of states. Distribution and time correlation are switch selected, with the following sequence of combinations possible:

<u>Number</u>	<u>Distribution</u>	<u>Time correlation</u>
1	flat	none
2	medium	none
3	medium	medium
4	bell	none
5	bell	high

The number of states is voltage controllable.

Stored random voltages

2 identical units here, called E and F, share three control voltage inputs, called skew, degree, and chaos.

When centered, the skew does nothing to the random voltage, but when turned left or right, the average voltage will move accordingly, with the probability distribution reshaped (skewed in one direction).

Degree establishes the degree of randomness in the output signal.

Chaos describes the shape of the probability distribution. Low chaos would suggest mostly small variations, with occasional large deviations from the norm. High chaos results in all levels of deviation having equal probabilities.

An interesting application for the 266e is the randomization of control voltages. For this, apply the control voltage to the skew input and adjust the degree and chaos for the desired uncertainty.

Settings of all pots and switches can be locally stored and subsequently recalled by the model 225e or the 206e preset manager.

To connect or disconnect this module from the central library function, push the remote switch. A lighted red LED signifies a connection.

Model 267e Source of Uncertainty with Filters

267190412

The Model 267e combines a noise source, two random voltage sources, and two voltage controlled filters.

Noise is dispensed in three flavors. Integrated white noise has a "low" spectral bias (-3 db/octave). Musically "flat" noise has a flat spectrum (constant energy per octave) and is a particularly useful source for subsequent processing. White noise is electrically flat, but musically balanced toward the "high" end of the spectrum (+3 db/octave).

Fluctuating Random Voltages are continuously variable, with voltage control of bandwidth over the range of .05 to 50 Hz, making possible changes that vary from barely perceptible movement to rapid fluctuation. Applied pulses sample these voltages, providing stored random voltages with arbitrarily wide, voltage controlled time correlations. Externally applied control voltages may be passed through unmodified, or may be randomized to any desired extent.

With nothing connected to the inputs, the both filter inputs are normalized to the flat white noise described above. Connect a signal to the input and you're filtering the signal.

The bandwidth adjustment determines the filter's passband, which can vary (inversely) from a few octaves to as little as one semitone. An external voltage can be applied to voltage control the bandwidth.

The frequency control establishes the filter's center frequency, which ranges from 31 Hz to 4 kHz, and can also be voltage controlled.

Both the center frequency and the bandwidth, as well as the amplitude, can be modulated. Apply a signal to the "mod in", and use the switch to select any combination of amplitude, frequency, or bandwidth modulation. The modulation knob and an applied control voltage determine the depth of modulation.

The 267e's settings can be stored and retrieved with a 225e or a 206e preset manager.

To connect or disconnect the module from the central library function, press the remote enable switch. A lighted LED denotes a connection.

Model 272e Quad Polyphonic Tuner

272110904

Four tuners, all sharing a common data base, which consists of 20 "slots", with each slot assigned to an F.M. station. Slots (and therefore stations) can be selected with control voltages, either sampled or continuous.

Antenna setup

Locate the two connectors on the back of the instrument (the same boat the 272e is installed in). One is a standard Motorola antenna socket, the other a blue banana jack. Connect the supplied antenna to these. Power on the system; a red LED should be illuminated on the antenna, indicating that power is applied. Locate the antenna above the system and away from large metal objects.

Station assignment

Press the "auto assign" button to initiate a procedure that automatically assigns the stations with the best signals to the twenty slots. The display will read "scan" until the assignment is complete.

Stations may be assigned manually. Select a desired "slot #" on tuner A and dial in the frequency of the station you'd like occupying that slot. Stations may be deleted; just press "delete" while displaying the station on tuner A. Stations occupying slots above the deleted one will drop down one slot, thus leaving no unfilled slots.

Tuner A serves as a master - it is the only tuner capable of assigning new stations to slots.

Station selection

Stations may be selected with continuous control voltages ("S&H" and "advance" LED's off). With the "slot" LED lit, a tuner's slot# will be displayed and selected with a sensitivity of .5 volts per slot, and the knob can be used to alter the slot number. When "frequency" is displayed, the entire F.M. band is spread over the 10 volt control voltage range, and the accompanying knob may be used to alter the (frequency of slot 0 only).

With "S&H" illuminated, the control voltage will be sampled by an incoming pulse, and with "advance" lit, an applied pulse will simply advance a tuner's slot number.

Polyphony

The 272e incorporates a polyphonic resource, with the four tuners sequentially providing "notes" with variable attack and decay times. The sustain switch offers the possibility of sustaining the "notes" as long as the incoming pulse is above the 5 volt threshold. Red LED's show the status of each tuner.

Settings of pots and switches, as well as station assignments, can be locally stored and subsequently recalled by the model 225e or 206e preset manager.

To connect or disconnect this module from the central library function, push the remote switch. A lighted red LED signifies a connection.

Note:

“Seek Parameter” Editing. If Auto Assign is not providing enough options, press and hold Auto Assign to get “SP Edit”. Then you can use the pots to raise the thresholds for seeking. With version 30.9 slots are permanently assigned upon scanning. (With 30.8, changing stations by hand will remain saved but are not assigned globally.)

Model 281e Quad Function Generator

281090825

The 281 has four function generators organized in 2 pairs. The following describes the top pair (A&B), but applies to the bottom pair as well (C&D).

The two topmost generators, A and B, normally function independently, but can be paired to operate in a quadrature mode.

Independent operation

A momentary switch selects one of four modes: transient, sustained, cyclic or none. On receipt of a pulse, output voltage A ramps up to 10 volts at a rate determined by the sum of an applied control voltage and the setting of the attack time knob. If in the sustained mode, the voltage will stay high as long as the input pulse is maintained. If not in the sustained mode, or when the input pulse terminates, the output ramps down to zero at a rate determined by the sum of the decay voltage and the setting of the decay knob. If no mode is selected, incoming pulses will have no effect – envelopes will be initiated by internal MIDI signals.

At the end of the decay, a pulse is generated and applied to pulse out A. If in the cyclic mode, the cycle now repeats.

Same for section B.

The time range for both attack and decay is from .001 to 10 seconds. The scale is linear from .001 to .03 seconds (input value from 0 to 3/8), and exponential from .03 to 10 seconds (input value of 3/8 to 1).

Outputs may be OR'd together, with one scaled and one at full value. The OR outputs may be used to establish an initial attack transient followed by a sustain at some lower value. Other applications will occur to you, but keep in mind that the OR levels are not stored as part of a preset.

The Quadrature mode:

Generators A and B operate in tandem to provide more complex envelopes. The quadrature mode is toggled by a push switch and indicated by LED's near the outputs.

As before, a pulse applied to the A input triggers the attack phase of A. When A's attack is completed, B begins its attack while A stays high. When B's attack is complete, A begins its decay while B stays high. And finally, when A's decay is completed, B begins its decay.

The trigger logic for the quadrature mode is derived from section A. If set to the sustain mode, A will stay high until the end of the initiating pulse. If A is in the cycle mode, the cycle repeats when B's decay ends.

Remote Enable: The 281e's settings may be stored and retrieved with the model 225 or the 206e preset manager. To connect or disconnect this module from the central library function or internal bus, push the remote switch. A lighted red LED signifies a connection.

In conjunction with the 225e, the 281e can monitor the internal MIDI bus, responding to note on and note off messages as well as controller 64 (sustain) as if they were pulse inputs. Sections from top to bottom (A-D) respond to internal bus A-D respectively.

To perform this function, the device select switches (on back of unit) **MUST** be set to device A. To read the device select code, depress either of the quadrature switches for a couple of seconds. The 225p or the 206p will display "module 281 A1" or "module 281 A2" if the switches are set for A. Additionally, the code version number will be displayed.

Note that to load or display firmware for this module, you must use the quadrature switches instead of the remote enable switch. There are two computers; load each separately, using first one, then the other quadrature switch.

For further explanation of the above features, please consult the description of the 225e MIDI/USB Decoder.

Model 285e Frequency Shifter / Balanced Modulator

285090430

The 285e consists of two independent sound processors: a frequency shifter, and a balanced modulator.

Frequency shifter

Shifts the frequencies of applied signals both up and down using either an internal or external reference source. The voltage controllable internal reference frequency can range between 1 and 1 kHz and can be modulated with an applied signal. The external reference can be anything from a simple sine wave to a very complex signal.

This module can generate an interesting illusion of depth, when the outputs are sent to a stereo pair and the shift frequency is set to just a few Hz.

Balanced Modulator

Performs the functions of classic ring modulation, plus adds some new tricks. As in the frequency shifter, the internal reference frequency is voltage controllable, can vary from 1 to 1kHz, and can be modulated with an applied signal. The external reference can be whatever you like, with the complexity of the signal determining the complexity of the outcome.

A second output on the ring modulator can pan between the unmodified input signal and the ring modulated version. This panning may be voltage controlled.

All the settings of this module can be stored and retrieved with the 225e or 206e preset manager.

Note that when displaying the firmware versions or loading new firmware, you must use the reference switches to select the module's section. The module requires two firmware cards, labeled 285F (freq) and 285B (balanced).

To connect or disconnect this module from the central library function, push the remote switch. A lighted red LED signifies a connection.

Model 291e Triple Morphing Filter

291090919

The 291e consists of three voltage controlled filters which can be operated independently or in parallel.

The amplitude, center frequency, and bandwidth of each filter may be independently voltage controlled. Each may be modulated with externally applied signals.

The morphing capability might be described as moving through a series of snapshots of the filter, with each snapshot consisting of a complete description of the filter parameters, and each parameter continuously varying between snapshots. Morphing is accomplished with an applied voltage, or alternatively can be initiated with a pulse, with each stage time independently set. From one to eight stages may be employed.

To edit a stage, select a desired stage with the red edit select switch. A red LED indicates the selected stage, and the green LED in the ninth position signals the play mode. The green switch toggles the play mode. Note that editing can be performed while in the play mode, allowing you to perceive the dynamic effect of changing parameters.

The central switch selects one of the three individual filters (nodes) for editing. Use the rotary encoders to adjust the values for amplitude, bandwidth, and frequency for each node. Note that amplitude affects only the summed output.

These three parameters may be modulated by signals applied to the modulation inputs. Use the switch to select amongst 7 combinations of modulation types, and the rotary encoder to adjust the modulation intensity.

The LCD will display the exact levels as well as the modulation amount:

A: 99 B: 56 F: 3.5k
M: 98 Sust T: 4.0

Morphing

A variety of means for progressing through the filter stages is provided. The control voltage input can serve two functions:

- 1) A voltage applied to the morph input will select a filter stage, with the selected number of stages spread over the 10 volt control range. This mode is enabled with the entry of "control voltage" in the bottom line of the display. In this mode, pulses are disabled, and "control voltage" is displayed for all stages.
- 2) If "control voltage" is not selected, then the applied voltage multiplies the stage time from 1 to 10. The voltage will affect all the stage times.

To automatically progress through the defined filter stages, use the edit select switch to select a stage; then enter a time value for that stage; successive stages will be advanced according to the times associated with each stage, which can range from .01 to 10 seconds.

This assumes that "Free" is entered in the center field in the bottom line. "Cycl" is similar, but loops the filter to the first stage. "Enbl" will permit the stage to be advanced only if an applied pulse is high, extending the time until the pulse goes high. "Sust" is the opposite, permitting advancement only with a low pulse, and inhibiting it when high. A "Puls" or a "Stop" inserted here will unconditionally stop the morphing at the specified stage, waiting for a pulse to advance immediately to the next stage ("Puls") or to the first stage ("Stop").

If the field identifier (a, b, f, or m) is capitalized, the filter will smoothly morph to the new value of the field. If the identifier is lower case, the filter will jump to the new value. Note that the fields are separate; a signal may jump in frequency while its level is slowly changing. The time field determines the stage time in either case.

To move the cursor between the identifiers, and the time field, press the data wheel. A sustained press allows the LCD contrast to be adjusted. Press it again to store the displayed value.

A solo switch, selecting one of the three nodes, proves convenient for editing, and is available when monitoring the all output. An expand input allows ready expansion of the filter; just plug in another 291e for an additional three nodes.

The 291e's settings can be stored and retrieved with the model 225e or 206e preset manager.

292e Dynamics Manager

292050101

Functionally identical to the original 292, with the exception of two new features - the 292e has velocity inputs, allowing controllers to control note volumes with performance gestures. And its settings can be stored as a part of a 200e series preset.

Level: The 292e sports four independent voltage controlled amplifiers. Each has a signal input and output, a control voltage input that varies the unit's gain from -120 to + 3db, an offset adjustment, and a velocity input. Velocity adds further control to the gain when employed (usually from a controller equipped with velocity output), but it has no effect when unconnected.

MODE: A three state switch selects one of three operating modes: straight gate (VCA), lowpass filter (VCF), or a combination of the two, in which the spectral response varies as the gain is changed.

Frequency domain gating can impart a dynamic tonal variation to sounds that gives the listener a sense of absolute loudness. This quality is characteristic of all acoustic instruments (the harder you strike, pluck, or blow, the richer the overtone structure).

A mix of the four output signals is also provided.

Remote Enable: Gain adjustments and switch positions may be stored for later recall by the Preset Manager, part of the MIDI/USB Decoder model 225e or the Mixer model 206e. A push button switch enables (or disables) this remote connection from the central library function; an LED indicates the current status.

Internal MIDI bus response: In conjunction with the 225e, the 292e can also monitor an internal MIDI bus, responding to the velocity byte of MIDI note on messages. If--and only if--the module ID is set to A and if the module is "remote enabled," signals A-D will respond to bus A-D respectively.

For further explanation of the above features, please consult the description of the 225e MIDI/USB Decoder.

296e Spectral Processor

296110930

This is a multifunction 16 channel bandpass filter with separate voltage controlled amplifiers (VCA's) and envelope followers associated with each channel filter. We'll discuss several applications forthwith – you'll undoubtedly come up with more of your own.

Programmable filter

Plug in a signal to either of the cross-connected inputs. It will be connected to all 16 of the filter sections. Press the DISP switch 'till "A levels" is illuminated, and turn the morph control counterclockwise, thus illuminating the orange LED. The three "SPEC-TRUM XFER" LED's should be off. The "all" output is now the sum of all 16 filters, each of whose amplitude response is governed by one of the 16 touch-controlled potentiometers. The unit now functions as a simple 16 channel bandpass filter, with the spectral shape indicated by the illuminated potentiometers. Touch a potentiometer to alter the corresponding filter's response.

Morphing filter

Similarly, select the "B levels", crank the morph control clockwise to illuminate the yellow LED, and adjust the potentiometers to the desired B response. We now have a second response curve stored for the 296e, and we can use the morph control to pan between the two curves. The actual net filter response can be observed by selecting "progrm", while the two curves can be edited by selecting "A levels" or "B levels".

By using a control voltage to rapidly alter the degree of morphing, we can generate interesting new timbres. A knob associated with the morph input ("A/B") determines the control voltage's effect, and a "sig in" allows for audio modulation of the morph level.

Split filter

By monitoring only the odd or even outputs, we've effectively split the filter into two parts, with the odd filters summed to the "odd" outputs and the even numbered filters directed to the "even" outputs. To complete this separation, connect separate signals to the odd and even inputs.

*(The little symbol between the connectors indicates this sort of connection: when only one patch cord is connected, the empty side will **also** receive the applied signal. When both sides are connected, the left side will drive only the odd numbered filters, while the right will drive only the even.)*

Comb Filter

An interesting effect, particularly in stereo, can be created by separating the odd signals from the even. The result is presented at the “*COMB OUTPUTS*”. The level controls have no effect on these outputs.

Spectral display

With the “*DISP*” section on “*envlps*”, the potentiometer LED’s will display the real time spectrum of the applied signal(s). The individual outputs of this display are brought out to banana jacks immediately above the potentiometers. These envelope followers can be routed anywhere a control voltage that responds to a specific range of frequencies is desired. The envelopes contain no frequency components; their “*decay times*” are adjustable, and can be extended for a long time.

With the “*DISP*” section on “*decay*”, a spectrum of decay times is presented; each may be altered with the associated potentiometer.

Voltage controlled filters

The 296e incorporates voltage controlled amplifiers (VCA’s) on each of the 16 bandpass filters. By applying varying control voltages to the VCA inputs (located directly beneath the potentiometers), rather complex dynamic spectra can be realized. The control voltage inputs are displayed in “*progrm*”.

Spectral transfers

By analyzing the spectrum of a sound applied to the “*odd*” input, and applying the spectrum to the signal from the “*even*” input, we can perform a sort of vocoding. To conserve several patchcords, choose “*odd > even*” in the “*SPEC-TRUM XSFER*” section. The necessary connections will be accomplished internally, the appropriate green LED will light, and the signal emerging from the even output will have (approximately) the spectrum of the odd signal input imposed on it. Note that the intermediate operation of simultaneously illuminating both the “*odd > even*” and the “*even > odd*” LED’s exchanges the spectra of the two inputs, potentially resulting in some ridiculous sounds.

You’ll have to use some patchcords to map further correlations. Use the envelope outputs to drive VCA inputs in whatever pattern you conceive.

If you're fortunate enough to possess two 296e's, you can perform a more accurate spectral transfer, eliminating the inaccuracy introduced by the odd/even business. The second 296e will analyze the sound applied to its input, and apply the spectrum to an internal bus. To complete the operation illuminate the "ext > all" LED in the first unit. The spectrum will now be transferred to the signal applied to the input, resulting in a vocoded signal at the "all" output. For some even more non-predictable sounds try simultaneously engaging the "ext > all" mode on both 296e's.

"*PRE-EMPHASIS*" controls are provided that allow one to accentuate the treble frequencies that may suffer in the spectral transfers. The math is tricky, but the controls work.

Sampling envelopes

Pressing the "freeze" switch or applying a pulse will freeze the output envelopes, but in different manners, depending on the setting of the "DISP" LED's. If either the "A levels" or "B levels" LED is illuminated, the envelopes will be displayed for the duration of the freeze signal, and will become the new A or B spectral response on its release. In other modes, the envelopes will simply be frozen for the duration of the applied pulse or switch closure, but they will not be stored.

All of the 296e's data with the exception of the "*PRE-EMPHASIS*" control settings may be stored as part of a preset. A preset manager (206e or 225e) is required for this trick.

User interface

When using the interface to draw in levels with your finger a slower swipe will generate the most accurate result.

297 Infinite Phase Shifter

297091218

The Infinite Phase Shifter displaces the phase of an applied signal by up to 1800 degrees, depending on frequency and number of stages selected. The phase shifted signal may be combined with the original to create a moderately warped comb filter with complimentary outputs. Notch density and depth can be varied through feedback (resonance) and stage selection. A wide range sweep oscillator enables the familiar cyclical phase shift effect.

All parameters (phase shift, notch depth, sweep rate, sweep depth, resonance) are voltage controlled, with processing control inputs where appropriate. A built-in envelope follower facilitates the creation of amplitude-dependant effects.

The 297 is capable of “barber pole” phasing, with the phase shift (and the consequent filter peaks and notches) continuously moving in one direction. Unique circuitry provides (or consumes) the extra time involved in this process. The rate of changes can be varied up to 2.5 octaves per second in either direction and is voltage controllable.

Note: the 297 is not an “e” module and does not save it’s parameters.

APPENDIX: A

MIDI Hardware connections:

With the e-series there is a MIDI I/O panel that comes with your 225e. Please connect the back of the 225e with the MIDI I/O panel with the provided 10-pin cable. But since neither MIDI Out nor USB were implemented on the 225e, it would be sufficient to use the 2pin header connection. On the 225e there are pads for a 2-pin connection for MIDI In at header labeled P7. Pins 1 and 2 of this connection can directly connect to pins 4 and 5 of a 5-pin DIN jack. This is the same for pins 1 and 2 of any header labeled for the 218e MIDI connection.

FAQ's about the different MIDI connector boards:

Can I connect the 225e with the h-MIDI board?: Yes. But if you use the blue h-series “h-MIDI” board, it would only be possible to connect the 225e using the pins 1 and 2 labeled for 218e and the connecting to 225e header at. The 10pin of the h-MIDI board is NOT compatible with the 225e.

But this 2-pin option leaves open the possibility of the connecting the 226h, 225e, and even the 225h simultaneously (If the 225h is connecting to USB while the 225e is connecting to the 5-pin DIN.)

Can I connect the 225e to the Easel MIDI input? Yes. If you have the connector that is labeled “225h/e” on the newer Easel power supplies, this is the simple connection. This connector can connect MIDI input to either the 225h or 225e.

But if you have any older Easel power supply you CAN use the pins 1 and 2 for the 218e, as explained above. But this requires using the 2-pin P7 header on the 225e.

Why aren't the 225e and 225h ALWAYS compatible on the 10pin connector? The first design of the 225e had a pinout that did not agree with proper USB implementation. And so when USB1.0 was integrated back on to the h-series MIDI I/O cable, a new pinout was devised. (However, the 225e I/O board does have USB “footprints” that could be soldered to in the future for USB2.0 connections.)